

Supplement 12 - POWERPLUS SPORT DOUBLE BURNER BMK-008

The technical content of this document is approved under the authority of the DOA Ref.: EASA.21J.351

SECTION 1

1.0 Introduction

This supplement defines the maintenance and inspection requirements for the Ultramagic Powerplus (BMK-008) Double burner. Sections 1 to 5 detail the maintenance procedures and the parts used in the burner construction. Section 6 details the annual / 100 hour inspection and test requirements.

The Airworthiness Limitations section is FAA approved and specifies maintenance required under §§43.16 and 91.403 of the Federal Aviation Regulations unless an alternative program has been FAA approved.

For US operations, only the items listed in 14 CFR Part 43, Appendix A may be accomplished as Preventative Maintenance items.

For U.S. operations, maintenance must be performed in accordance with the requirements of 14 CFR Part 43.3 Persons authorized to Perform Maintenance, Preventative Maintenance, Rebuilding, and Alterations.

For US operations please refer to Unit Conversion Table (Supplement 10), whenever necessary.

1.1 Applicability

The information contained in this supplement applies to all Ultramagic Powerplus BMK-008 Double burners as defined by drawing 2032-0000.

1.2 Replacement Parts and Procedures

The burner has been designed and constructed using carefully selected components and materials. In order to ensure the continued airworthiness of the burner, it is essential that only parts supplied by Ultramagic or by a supplier approved by Ultramagic be used. The use of parts from any other source is strictly forbidden.

Always quote the spare parts reference codes shown in our Parts Catalogue (Issue 5 and on, available on Ultramagic website) to place an order.

Maintenance procedures must be carried out in accordance with the instructions contained in this supplement.

1.3 Approved Maintenance and Inspection Personnel

In order to ensure the continued airworthiness of the burner, maintenance and formal inspection may only be carried out by Ultramagic, organisations approved by Ultramagic or by organisations approved by the national airworthiness authority in the country of registration.

1.4 Welding and Welders

If for any reason a repair requires the use of welding, the following limitations apply:

- All welding must be of the TIG (Tungsten Inert Gas) electric arc type.
- All welding must be carried out by a welder approved to the appropriate standard by the national airworthiness authority in the country of registration.

1.5 Maintenance Records

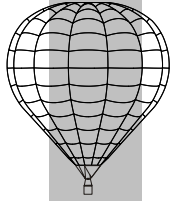

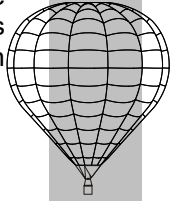

Whenever maintenance work of any kind is carried out on the burner, the work must be inspected and approved by a person or organisation approved by the national airworthiness authority in the country of registration. Maintenance work must be recorded by a suitable entry in the equipment maintenance record and must include the following information:

- A description of the work performed.
- The completion date of the work.
- The name of the person (and organisation if applicable) performing the work.
- The name of the inspector approving the work.

1.6 Technical Support

If technical assistance is required, contact Ultramagic. Always quote the burner part and serial numbers.

1.7 Safety

When connected to a fuel cylinder, the burner is capable of generating a very large, high temperature flame. Exercise care when carrying out maintenance work and observe the following rules.

- Always wear protective eyeglasses.
- Observe the usual rules for the handling of LPG.
- When test firing, wear suitable protective gloves.
- Always make sure that the burner has been completely vented of fuel before removing any components.
- Always make sure that the burner is cool before commencing work.
- Never look down onto the coil when the burner is connected to a fuel cylinder or when pressure remains inside the burner.
- When test firing, never stand down wind of the burner.
- Prior to test firing, make sure that the area is clear of personnel and animals.
- When test firing, make sure that the burner is properly supported and not able to fall or tilt unexpectedly.
- Never smoke or allow naked flames or other sources of ignition near the burner.
- Always use the correct tool for the job.

SECTION 2

2.0 Airworthiness Limitations

2.1 Approval Statement

This manual provides the maintenance information required by EASA CS-31HB .82 and FAR 31 section 31.82.

2.2 Mandatory Replacement Time

There are no components in the Powerplus BMK-008 Double burner, which must be replaced after a fixed length of time.

2.3 Inspection Interval

The maximum inspection interval for the burner is 100 hours operation or one year; whichever is the sooner. The requirements for this inspection are defined in section 6.

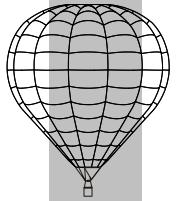

SECTION 3

3.0 Technical Description

3.1 General

The burner is a device for converting the fuel stored in the fuel cylinders into heat energy. This energy is used to heat the air inside the balloon envelope and thus provide the means of inflation and altitude control during flight.

Fuel is supplied to the burner through the flexible hoses. The fuel enters a machined valve block whereupon the fuel is distributed to the various valves and pressure gauge in readiness for use. The burner is provided with completely independent left and right fuel circuits and thus provides duality of all major functions.

The burner is provided with the following major features:

- Burner gimbal mounting
- Burner cans
- Left and Right Vaporising coils
- Fuel hoses
- Left and Right Main valve assemblies
- Left and Right Liquid valve assemblies
- Left and Right Pilot Regulator Valve assemblies
- Left and Right Igniter assemblies
- Left and right Pressure gauge assemblies
- Left and Right Liquid fire jet assemblies
- Left and right Pilot light assemblies
- Left and right Safety Buttons

The burner is provided with a two-stage main valve action. Operation of the main valve to the intermediate position activates the main burner. Further operation of the main valve to the fully open position activates both the main and liquid burners enabling approximately double power output through single hand operation.

Note that all burner maintenance work must be conducted in a clean environment.

The Powerplus Double burner may be seen in Figure 1 and the features and functions detailed above are described in the following paragraphs:

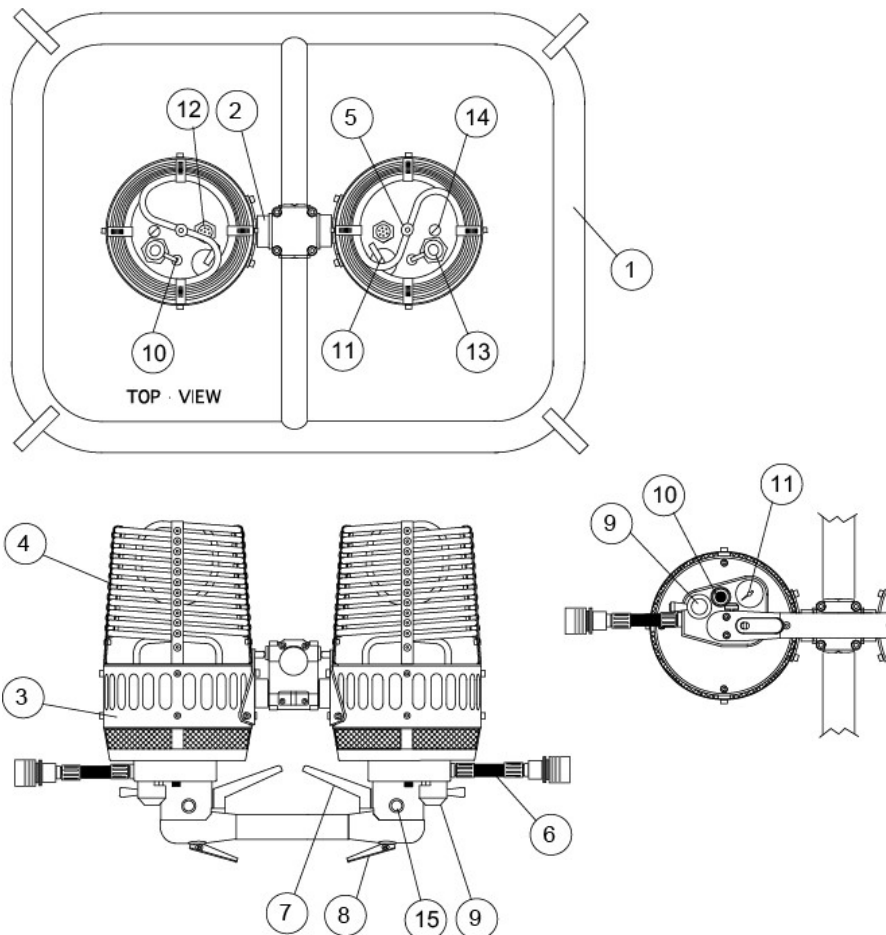
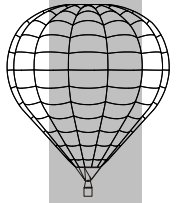

ITEM	DESCRIPTION	ASSEMBLY
1	ULTRAMAGIC BURNER FRAME	REF ONLY
2	BURNER GIMBAL MOUNTING	SEE SECTION 3.2
3	BURNER CAN	SEE SECTION 3.3
4	VAPORISATION COIL	SEE SECTION 3.4
5	COIL CONNECTION COLUMN AND BLAST VALVE SLEEVES	SEE SECTION 3.5
6	FUEL HOSES	SEE SECTION 3.6
7	MAIN VALVE ASSEMBLY	SEE SECTION 3.7
8	LIQUID VALVE ASSEMBLY	SEE SECTION 3.8
9	PILOT REGULATOR ASSEMBLY	SEE SECTION 3.9
10	IGNITER ASSEMBLY	SEE SECTION 3.10
11	PRESSURE GAUGE ASSEMBLY	SEE SECTION 3.11
12	LIQUID FIRE JET ASSEMBLY	SEE SECTION 3.12
13	PILOT LIGHT ASSEMBLY	SEE SECTION 3.13
14	PILOT LIGHT FUEL FILTER	SEE SECTION 3.14
15	SAFETY BUTTON	SEE SECTION 3.15

Figure 1

3.2 Burner Gimbal Block Assembly

The burner is provided with a centre gimbal block assembly allowing two-axis movement of the burner. With the exception of the burner gimbal mounting, the gimbal block assembly is standard to the MK21 range of burners and maintenance instructions are provided in a separate maintenance supplement.

The burner gimbal block assembly and mounting configuration may be seen in Figure 1.

3.3 Burner Can

The burner can is a welded stainless steel construction. It provides a degree of mechanical protection to the components mounted inside the burner. The can is mounted onto the valve block via a series of mesh panels using screw fixings. The can provides the mechanical

support for the vaporisation coil and attachment to the gimbal mounting arrangement. The can may be seen in Figure 1.

3.4 Vaporisation Coil

The vaporisation coil is connected to the outlet of the main valve using a machined coil column and “O” seals fitted to the inlet tube of the coil. The function of the coil is to preheat the fuel before leaving the jet ring in readiness for combustion. The coil is a two start, welded assembly and is constructed from stainless steel tube, a special Coander jet ring with fixed jets and coil supports.

When the main valve is opened, fuel enters the coil through the inlet tube. The fuel rises to the top of the coil and then descends through the coil spiral until it exits through the jet ring.

The vaporisation coil configuration may be seen in Figure 1.

3.5 Coil Connection Column

The interface to the vaporisation coil is through a machined column screwed in to the upper surface of the valve block and sealed with an “O” seal on the mating face. The column is provided with a precision-machined bore to accept the two “O” seals fitted to the coil inlet tube.

Note that the column is used to create the seal to the main valve and removal of the column will therefore break the pressure integrity of the burner. It is very important therefore to ensure that the burner is completely vented of fuel prior to removal of these components.

The coil connection column and the blast valve sleeve configuration may be seen in Figure 3.

3.6 Fuel Hoses

The fuel hoses link the burner to the fuel cylinders. They are terminated with a choice of REGO®, TEMA® or Fastflat self-sealing connectors. The hoses are specially selected to withstand the operational fuel pressures and the wear and tear associated with use and handling. The fuel hose is supplied as a pre-fabricated assembly using armoured hose and swaged end fittings.

The process of swaging the end fitting onto the hose requires the use of special tooling. The use of any fuel hose other than that supplied by Ultramagic is therefore strictly forbidden.

3.7 Main Valve Assembly

The main valve is used to control the main burner function of the burner by the activation of a “squeeze” type handle. The valve is a plunger type and uses a special sprung loaded rubber seal, bearing against a machined seat in the valve block to create the seal. When the valve handle is operated, the seal lifts off the seat in the valve block and allows the flow of fuel.

The valve stem is housed in a machined brass valve bonnet. A pressure tight seal is achieved between the stem and bonnet with the use of two “O” seals and a primary sprung loaded seal. The bonnet is sealed to the valve block using an “O” seal fitted in a machined groove in the bonnet mating face.

The main valve handle is provided with a special two-stage action. A mechanism links the main valve handle to the liquid valve. When the handle is moved to the first intermediate position, the main valve is opened. Movement of the handle to the second fully open position causes the liquid valve to open simultaneously enabling approximately double burner power from single hand operation.

The main valve configuration may be seen in Figure 10.

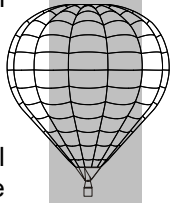

3.8 Liquid Valve Assembly

The function of the liquid valve is similar to the main valve described above and the method of sealing is identical. Note however that the liquid valve is only a single action and operation of the liquid valve handle activates the liquid fire function only.

Due to the dual action of the main valve and the associated link mechanism required to enable double action, the design of the liquid valve stem is different to that of the main valve. The stem is longer and has an additional hole to allow connection of the link mechanism. An additional spring loaded thrust assembly is provided underneath the valve handle. The handle is a squeeze action.

The liquid valve configuration may be seen in Figure 10.

3.9 Pilot Regulator Assembly

The pilot regulator may be considered as two sub-assemblies consisting of the regulator itself and the on/off valve mechanism.

The regulator sub-assembly consists of a lower body which screws in to the valve block, a sprung loaded piston and an upper body fitted with a small jet.

The regulator sub-assembly is screwed in to the upper surface of the valve block. An "O" seal fitted in a machined groove on the underside of the lower body forms the seal between the regulator and the valve block. The lower body is provided with a seal seat and this forms the seal to the on/off valve sub-assembly.

When the valve handle is operated, fuel enters the lower body through a small hole. Fuel passes through a small hole in the piston and exits in to the chamber between the piston and the upper body. The sudden increase in volume causes the fuel to vaporise. The fuel pressure in the chamber forces the piston down thus closing off the fuel inlet. Vaporised fuel in the upper chamber is vented off through the jet to the pilot light assembly. As the pressure in the chamber falls, the spring forces the piston to move forward and the cycle is repeated.

The piston is fitted with a small lower seal, which closes off the flow of fuel. A larger "O" seal is fitted inside the upper body and forms the seal between the piston and the body.

The on/off valve sub-assembly consists of rotary action knob acting about a valve bonnet. The bonnet is fitted with a stem and a valve seat, similar (but not identical) to the main and liquid valves. The stem is sealed to the bonnet using two "O" seals. An "O" seal fitted in a machined groove in the bonnet mating face seals the bonnet to the valve block. Rotation of the knob causes the stem to move backward thus breaking the seal to the regulator lower body.

A special filter is mounted inside the valve block and filters the fuel before entering the valve.

Note that the regulator lower body is used to create the seal to the regulator on/off valve. Removal of the regulator lower body will break the pressure integrity of the burner. It is therefore very important to ensure that the burner is completely vented of fuel prior to removal.

The regulator configuration may be seen in Figure 12.

3.10 Igniter Assembly

The Igniter Assembly is a "cartridge" type and is simply inserted into the bore provided in the valve block. The assembly is held in position by a grub screw positioned in the side of the valve block. The assembly is provided with an "O" seal to prevent the seepage of water from the upper surface of the valve block during operation.

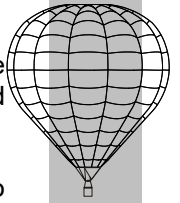

The assembly consists of a tube in which are housed a piezo igniter and an electrode permanently mounted in temperature resistant ceramic. The electrode and piezo igniter are electrically connected by a compression spring. When assembled, the piezo igniter makes contact with the electrode thus allowing the transmission of the high voltage to the electrode tip.

Upon operation of the piezo igniter button, a high voltage spark is produced between the electrode and a tag mounted on the side of the pilot light causing the pilot light to ignite.

The igniter assembly configuration may be seen in Figure 5.

3.11 Pressure Gauge Assembly

The pressure gauge is mounted inside a machined bore in the valve block. Access to the gauge is from the upper surface of the valve block.

A pressure tight seal is achieved with the use of PTFE tape and a taper thread on the gauge rear. The gauge is screwed in to a special retaining block fitted to the upper surface of the valve block. The retaining block is secured to the valve block by a single screw fixing. The retaining block also functions as a fuel link to the pressure gauge and the interface to the valve block is therefore sealed using an "O" seal. When in position, the inlet to the gauge is positioned in a tapping from the main fuel feed within the valve block. The gauge therefore provides an indication of the fuel cylinder pressure as soon as the fuel cylinder valve is turned on.

The face of the gauge is provided with a colour coded banding indicating the safe operating pressure range of the burner.

The gauge is fitted with a flow restrictor mounted in the rear. The restrictor is designed to protect the gauge from sudden pressure surges and to limit the fuel flow rate in the unlikely event of a gauge failure.

The pressure gauge configuration may be seen in Figure 8.

3.12 Liquid Fire Jet Assembly

The liquid fire jet assembly is mounted on the upper face of the valve block. The jet controls the flow of fuel when the liquid valve is operated. The assembly consists of a machined body fitted with multiple holes at the outlet. The body is sealed to the valve block using an "O" seal fitted in a machined groove on the underside of the jet body.

Note that the jet body is used to make the seal to the liquid valve jet and removal of the jet will therefore break the pressure integrity of the burner. It is therefore very important to ensure that the burner is completely vented of fuel prior to carrying out any work on the liquid fire jet.

The liquid fire jet configuration may be seen in Figure 3.

3.13 Pilot Light Assembly

The pilot light assembly is mounted directly above the regulator assembly. It is supplied with a small flow of vapour fuel from the pilot regulator assembly. The assembly consists of a stainless steel filter tube secured to the regulator upper body by a grub screw. The filter tube contains the air inlet to the pilot light and a series of mesh disks secured using split rings near the outlet. A second tube is secured to the filter tube using a small screw. This tube is provided with a series of holes to allow the flame to exit.

The pilot light element is fitted with a special tag. This tag is aligned with the igniter electrode and adjusted in order to maximise the spark "strength".

The pilot light assembly configuration may be seen in Figure 6.

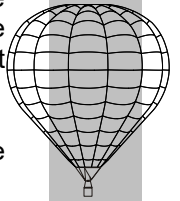

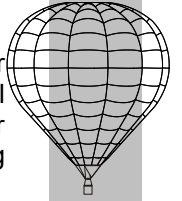

3.14 Pilot Light Fuel Filter

Fuel to the pilot light regulator is supplied by a dedicated tapping in the valve block. Prior to entering the pilot regulator, the fuel passes through a small filter. The filter is fitted in a special housing allowing it to be removed easily for maintenance. The housing is screwed in to the upper surface of the valve block and is sealed using a small "O" seal fitted in a groove in the housing mating face.

Fuel enters the housing through the filter mounted in the bottom and exits through a small hole near the top of the housing.

The pilot light fuel filter configuration may be seen in Figure 7.

3.15 Safety Button

Each of the main valve mechanisms may be locked in the ON position by operating the safety button fitted on the side of the external valve body. When the main valve handle is held in the open position and the button is simultaneously depressed and held, the main valve will be locked in the open position upon release. The button is spring-loaded and is released by further operation of the main valve handle.

The safety button configuration may be seen in Figure 13.

SECTION 4

4.0 Preventative Maintenance

4.1 General

The burner should be subjected to periodic preventative maintenance checks and preventative maintenance measures implemented if necessary. It is recommended that the period between inspections is once every three months or 25 hours operation, whichever is the sooner. The checks must incorporate the areas detailed below.

4.2 Burner Can Fixings

The four fixings used to secure the valve block to the burner can are very important. Removal of the fixings will allow the valve block to separate completely from the burner. Check therefore, that the four fixings located on the underside of the valve block are secure. If any of the screws are loose, completely remove the screw and apply a small amount of Loctite 243 to the thread. Re-assemble the screw and tighten.

4.3 General Cleaning

Check for the excessive build up of sooty deposits on the vaporisation coil and can. Some accumulation of soot is inevitable and is not detrimental to the burner function. However, excessive deposits are indicative of inefficient fuel combustion. If this is considered to be the case, contact Ultramagic for further advice.

Sooty deposits may be removed from the burner can and coil using a suitable cleaning solvent. When using a solvent, follow the manufacturers' safety instructions, particularly with regard to the use of breathing apparatus and ventilation.

4.4 Vaporisation Coil

4.4.1 Main Jets

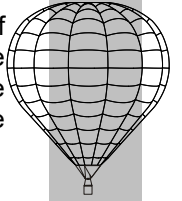

Check the main jets in the coil jet ring for excessive soot deposits and for the presence of foreign bodies within individual jet holes. Blocked jets can cause a reduction in the fuel flow rate and thus lead to an increase in the operating temperature of the coil. This could result in damage to the coil especially when operating at low fuel pressure. In the event that blocked jets are detected, they must be cleaned as specified in Section 5.3.

4.4.2 Coil Fixings

Check the fixings securing the coil to the can. Loose fixings must be tightened as described in Section 5.3

4.4.3 Coil Tubing

Check the tube used in the construction of the coil for damage including signs of cracking, serious indentation and deterioration of welded joints.

Serious indentation cannot be repaired and the coil must be replaced as described in Section 5.3.

If the coil tube has cracked or a welded joint has failed, the coil must be returned to Ultramagic for investigation. Replace the coil as described in Section 5.3.

4.4.4 Coil Support Rivets

Check the condition of the rivets used to fix the two halves of the coil supports together. In particular, check the condition of the rivets on the inside of the coil. All rivets must be in good condition and show no signs of damage due to over-heating.

If damage to any of the rivets is detected, contact Ultramagic for further advice.

4.5 Pilot Light Strength

Check the strength and height of the pilot light flame. A weak or short flame is indicative of a blockage or partial blockage of the pilot light jet or a fault with the pilot regulator. In the event that the pilot light flame is considered to be unacceptable, clean the pilot light jet as described in Section 5.7.

4.6 Igniter Spark

Check the strength of the igniter spark. A weak spark will make pilot like ignition difficult or impossible when using the igniter. If it is considered that the igniter spark is weak, adjust the spark gap as described in section 5.6. If this fails to improve the spark, it is possible that there is poor electrical continuity between the igniter and the pilot light. Check that the grub screw used to secure the igniter assembly and fitted in the side of the valve block, is tight (take care not to damage the aluminium thread in the valve block). Check that the pilot light assembly is secure. If it appears to be loose, make sure all fixings are tight.

If the above actions fail to improve the spark, the igniter will need to be removed and disassembled to determine the cause of the problem (see Section 5.6).

4.7 Fuel Hoses

Check the condition of the fuel hoses. Look for any signs of abrasion, kinking or other forms of damage. If any of the above are detected, the hose must be replaced in accordance with the instructions in section 5.13.

Fuel hoses must be obtained from Ultramagic. For safety reasons, fuel hoses are supplied assembled with the connector and pressure tested.

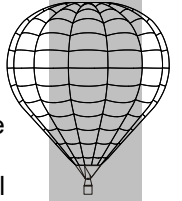

4.8 Pressure Gauge

Check the function of the pressure gauge as follows:

- Make sure that the burner is fully vented. Visually inspect the position of the gauge pointer and check that it is indicating zero pressure.
- Connect the burner to a fuel cylinder or a 7 Bar (100 psi) compressed air supply. If a fuel cylinder is used, measure the cylinder pressure first using a calibrated pressure gauge (contact Ultramagic for further details). Visually inspect the position of the gauge pointer and check that it is correctly indicating the pressure. Visually inspect the position of the gauge pointer and check that it is correctly indicating the pressure.

Upon completion of the test, ensure that the burner is safely vented.

If either of the above tests indicate that the gauge is faulty, the gauge must be replaced in accordance with the instructions in section 5.10.

Note: The pressure gauge is a sealed item with no serviceable parts. No attempt must be made to repair a faulty gauge. Gauge repair is by replacement only.

4.9 Burner Mounting

Check that all fixings used to secure the gimbal support to the burner cans are secure. Tighten the fixings if necessary. Ensure that the eight fixings securing the gimbal block are tight. Tighten if necessary.

SECTION 5

5.0 Repair and Maintenance

5.1 General

This section describes the procedures necessary to enable the removal, repair and replacement of the various assemblies, sub-assemblies and components used within the burner. Maintenance other than that detailed in the Section 4, (Preventative Maintenance) and Section 6, (Annual / 100 Hour Inspection) should not be carried out unless it is clear that there is a fault or there is a noticeable deterioration in the performance of any part of the burner functions. Remember, "If it ain't broke, don't fix it"!

Whenever a part or assembly whose removal breaks the pressure integrity of the burner is removed and replaced, the re-assembled joint(s) must be subjected to a pressure test. Connect the burner to a 7Bar (100-psi) compressed air supply and test the joint using leak detector fluid. If bubbles are detected during the test, there is a leak, which must be rectified before further burner use.

Prior to carrying out any maintenance work, ensure that the burner is completely vented of fuel and disconnected from the fuel supply. Remember to check that both left and right fuel circuits are vented.

5.2 Burner Gimbal Mounting

5.2.1 Gimbal Block

The gimbal assembly is identical to that used on the MK21 burners. For maintenance instructions, refer to Ultramagic Maintenance Manual Supplement Number 8.

5.2.2 Burner Gimbal Mounting

To remove the double burner gimbal mounting, refer to Figure 2 and proceed as follows:

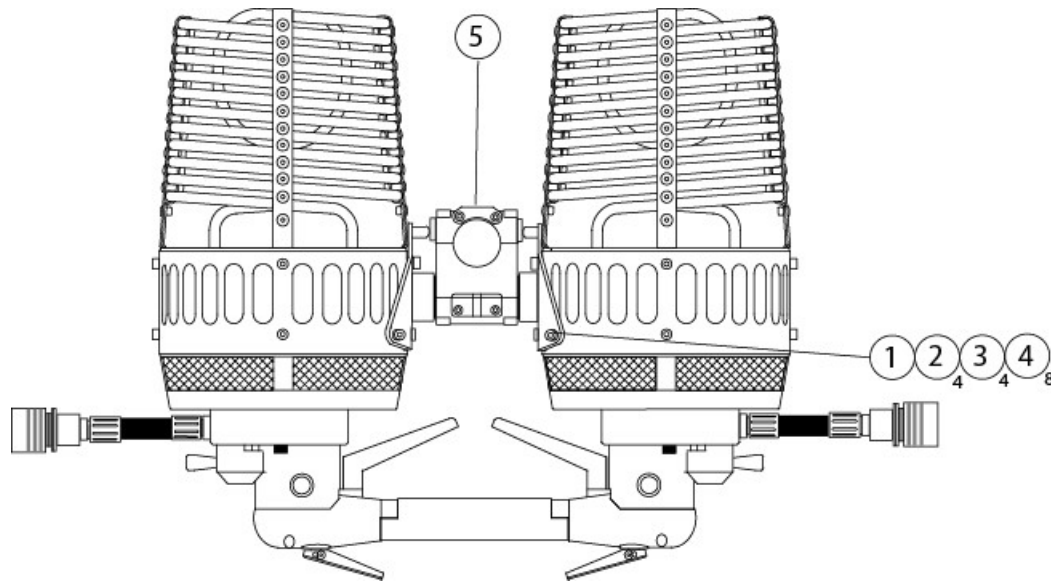

ITEM	DESCRIPTION	DWG / PART NUMBER
1	POWERPLUS DOUBLE MOUNTING BRACKET ASSY	CR-PPD-0135
2	M5x12 ST STL HEX DRIVE DIN 912 SCREW	CR-PP-0011
3	M5x16 ST STL HEX DRIVE DIN 912 SCREW	CR-PP-0013
4	M5 ST STL DIN 985 LOCK NUT	CR-PP-0111
5	ULTRAMAGIC GIMBAL BLOCK	2022 / 2500

Figure 2

- Refer to Ultramagic Maintenance Supplement No 8 and remove the burner from the burner frame.
- Ensure both burners are supported and then remove the gimbal block assembly.
- If coil removal is required, use a 4mm Allen key and an 8mm open-ended spanner to undo and remove the eight screws and nuts (items 2, 3 and 4 respectively). Thus the coil will rest free.
- Re-assembly is generally the reverse procedure to disassembly. If necessary, apply Molycote graphite grease to the bearing surfaces of the gimbal block and the mounting bracket. Refer to Ultramagic Maintenance Supplement No 8 for instructions covering the gimbal block assembly process.

5.3 Coil Removal

5.3.1 Removal of Coil from Burner

Since serious indentation in the coil tube cannot be repaired and weld faults must be returned to Ultramagic for inspection, coil maintenance is limited to the areas detailed below. To remove the vaporisation coil, refer to Figure 3 and proceed as follows:

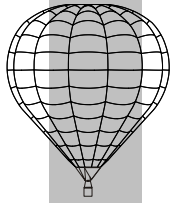

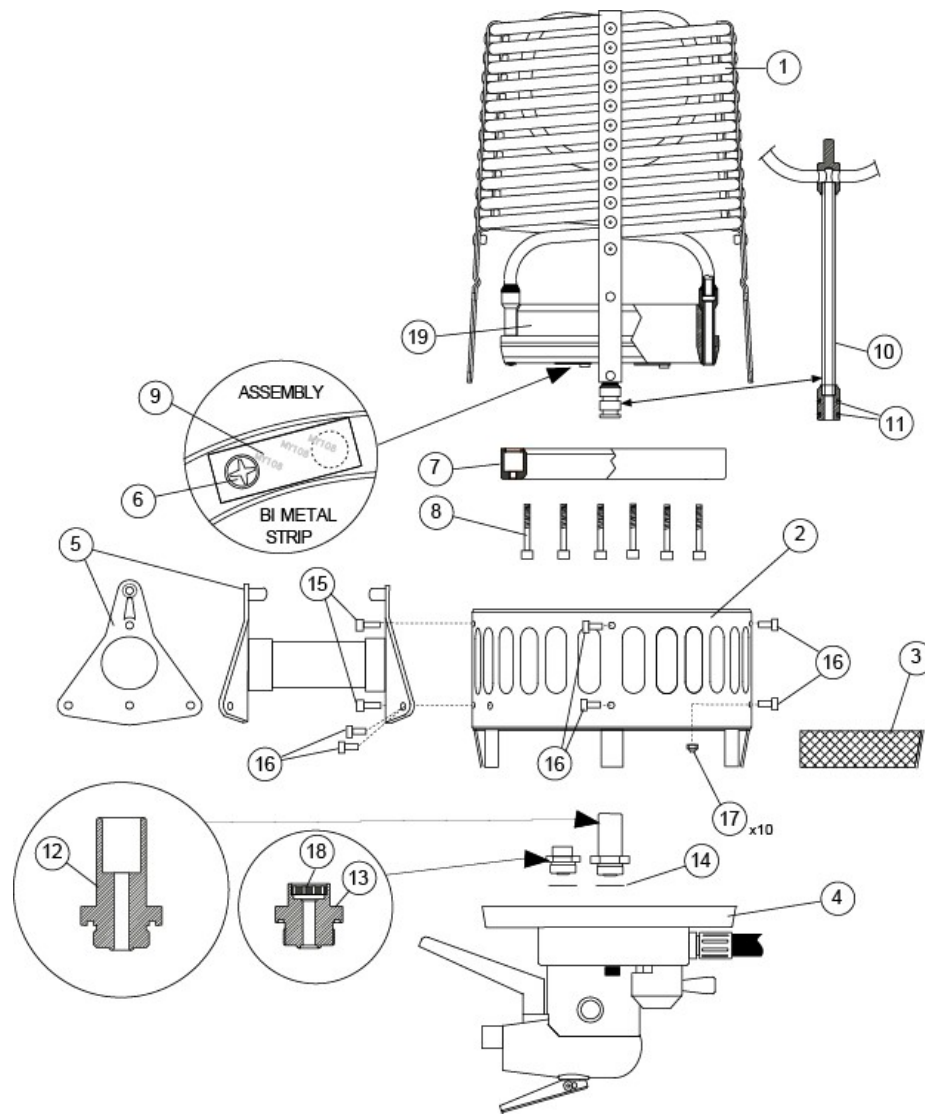
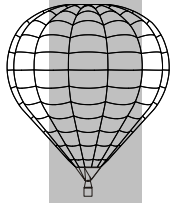

ITEM	DESCRIPTION	DWG / PART NUMBER
1	COIL AND COANDA JET RING	CR-PPD-0115
2	POWERPLUS DOUBLE CAN	CR-PPD-0016
3	BURNER CAN PROTECTION NET	CR-PPD-0134
4	POWERPLUS DOUBLE VALVE BLOCK RH	CR-PPD-D031
5	POWERPLUS DOUBLE GIMBAL MOUNTING BRACKET ASSY	CR-PPD-0135
6	M4x12 ST STL PHILLIPS PAN HEAD DIN 7985 SCREW	CR-PP-0041
7	LOWER MULTIHOLE JET RING	CR-PPD-0124
8	M5x30 ST STL HEX DRIVE DIN 912 SCREW	CR-PP-0016
9	JET RING BIMETAL STRIP	CR-PPD-0127
10	CENTRE COLUMN FITTING	D116/2
11	NB 3037 NBR 70 SHORE O-R SEAL	CR-PP-0327
12	BLAST VALVE SLEEVE	CR-PPD-0074
13	LIQUID CONNECTION JET	CR-PPD-0075
14	NB 2087 NBR 70 SHORE O-R SEAL	CR-PP-0326
15	M5x16 ST STL HEX DRIVE DIN 912 SCREW	CR-PP-0013
16	M5x12 ST STL HEX DRIVE DIN 912 SCREW	CR-PP-0011
17	M5 ST STL DIN 985 LOCK NUT	CR-PP-0111
18	LIQUID JET PLATE	D089
19	INNER JET RING	D123/2

Figure 3

- Ensure that the burner is completely vented of fuel.
- Using a 4mm Allen key and a 8mm open-ended spanner, undo and remove the seven fixings securing the coil support legs to the can.
- Carefully withdraw the coil from the burner.

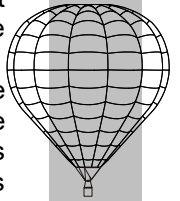

- Check the condition of the two “O” seals (item 11) fitted near the bottom of the coil inlet tube. The seals must be replaced if they show signs of deterioration such as damage due to over-heating, splits etc.
- Remove the “O” seals using a suitable soft tool to lift the seals out of the grooves. Take care not to damage the surface finish of the grooves. Check the condition of the surface inside the grooves where the “O” seals are fitted for any signs of deterioration. This is best achieved using a suitable magnifying glass. If significant damage to the surface is noted, contact Ultramagic for advice and to determine the most appropriate repair action.
- Replacement of the coil is generally the reverse procedure of removal. Prior to re-assembly, apply a thin smear of Krytox 125 grease to the “O” seals.
- Upon completion of re-assembly, connect the burner to a suitable compressed air supply not exceeding 6.8bar (100psi) pressure. Apply leak detector fluid to the joint between the coil and coil post. Open the main valve and check for signs of leakage. If any leaks are detected, the problem must be resolved before the burner is returned to service.

5.3.2 Disassembly of Jet Ring

The coil is fitted with a special Coander jet ring. The Coander effect is the propensity of a moving fluid to follow the profile of an adjacent boundary and this effect has been used in the design of the jet ring. Consequently the jet ring design is slightly more complex than more traditional designs.

The jet ring is fitted with special stainless steel bi-metal strips, which open and close and thus provide a degree of control of fuel flow rate as the temperature of the fuel in the jet ring varies.

To disassemble the jet ring, refer to Figure 3 and proceed as follows:

- Ensure the burner is completely vented of fuel.
- Remove the coil from the burner as described in Section 5.3.1 above.
- Inspection of the jet ring may reveal an accumulation of oily deposits on the outer surface. These deposits are not detrimental to burner performance provided that the deposit does not cause jet blockage.
- To prevent unnecessary work at this stage, check the condition of the jets for blockages etc. This may be done visually and by inserting a suitable piece of stiff wire in to each jet hole. Only proceed with further dismantling if it is considered that the jets require thorough cleaning or if the bi-metal strips require inspection or maintenance.
- The jet ring may be further disassembled if considered necessary. Using a 4mm Allen key, undo and remove the six cap head screws (item 8) from the under side of the jet ring.
- Withdraw the lower jet ring (item 7) from the upper jet ring (item 19).
- Check the condition of the internal jet ring faces. Carefully clean away any oil deposits or other contaminants.
- Check the condition of the bi-metal strips (item 9). These are secured to the underside of the upper jet ring. When the coil is cold, the strips should be in the “closed” position i.e. covering the inlet to the jet hole. Only remove the strips if it is considered necessary.
- Prior to removing the bi-metal strips, use a soft marker pen to mark the position of the strip to indicate which jet holes are covered by the strip.
- To remove the bi-metal strips, use a crosshead Philips screwdriver and remove the screw securing the strip to the upper jet ring.
- Replacement is generally the reverse procedure to removal. Ensure that the bi-metal strips are positioned correctly. Note that the seal between the upper and lower jet rings is formed by the conical fit of the two components. It is very important therefore to ensure that the lower ring is fitted square to the upper ring and that the six fixings are tightened correctly. Fit all six fixings finger-tight. Select any fixing and tighten a quarter turn. Select the diagonally opposite fixing and tighten a quarter turn. Continue to tighten all fixings, always as diagonally opposite pairs, a quarter turn each time, until all fixings are tight. **Use just an Allen screwdriver to tighten the screws. Over-tightening may result in permanent deformation of the multihole jet ring.**
- Prior to re-assembling the coil to the burner, check the seal between the upper and lower jet rings by connecting the coil inlet to a suitable compressed air supply of maximum

pressure 6.8bar (100psi) and using leak detection fluid around the joint. If leaks are detected, the problem must be resolved before the burner is returned to service.

5.3.3 Tightening of Coil Mounting Screws

To tighten the coil mounting screws, refer to Figure 3 and proceed as follows:

Using a 4mm Allen key and an 8mm open-ended spanner, tighten the eight-coil mounting screws and nuts (items 15, 16 and 17) if necessary.

5.4 Burner Can Removal

The burner can is a welded stainless steel assembly. Some indentation to the can is acceptable provided that the integrity of the fixings supporting the coil, valve block or burner mountings are not compromised and that the gimbal action of the burner is unaffected.

Small cracks in the can may be repaired by welding (see section 1.4).

If it is considered that the can must be removed for repair, refer to Figure 4 and proceed as follows:

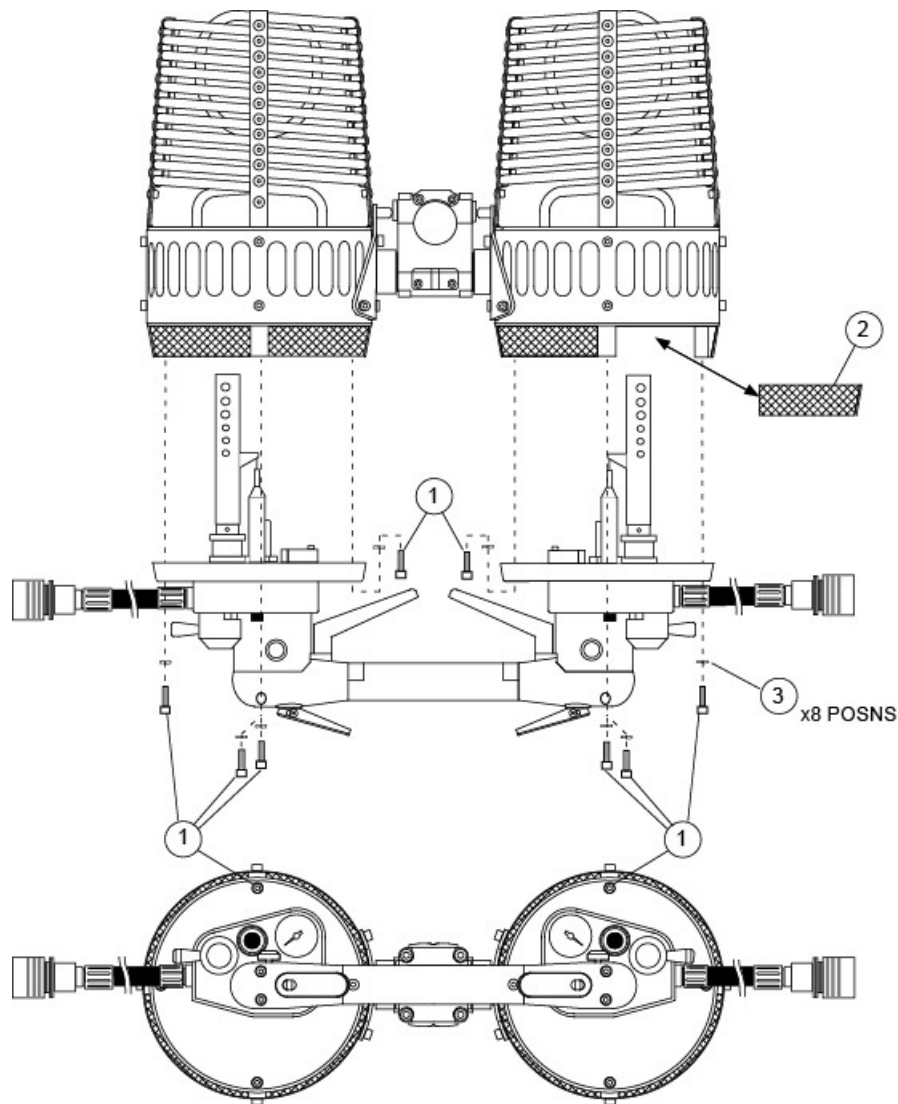

ITEM	DESCRIPTION	DWG / PART NUMBER
1	M5x16 ST STL HEX DRIVE DIN 912 SCREW	CR-PP-0013
2	BURNER CAN PROTECTION NET	CR-PPD-0134
3	M5 ST STL DIN 127 LOCK WASHER	MA-FE-0072

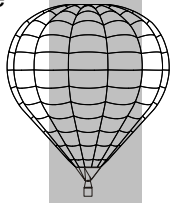

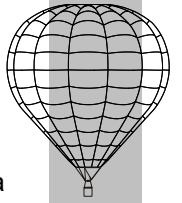

Figure 4

- Ensure that the burner is completely vented of fuel.
- Remove the burner from the gimbal mounting as described in section 5.2.
- Remove the coil as described in section 5.3.
- Prior to removing the can, mark the relative positions of the can and valve block using a soft felt tip pen at any convenient position on the internal faces where it will not be seen in normal operation.
- Using a 4mm Allen key, undo and remove the four fixings (item 1) located in the underside of the valve block. Note that upon removal of the fixings, the valve block is no longer supported and is free to be withdrawn. Make sure therefore that the valve block is supported before removing the fixings.
- The can is now free to be removed. Withdraw the can from the valve block. Withdrawing the can will allow the four mesh panels fitted between the can and the block to be removed.
- Replacement is generally the reverse procedure of removal. Align the markers to ensure that the can is assembled to the block in the correct orientation. Replace the three mesh panels by fitting the lower edge in the groove in the upper side of the valve block and trapping the upper edge behind the retaining strips fitted on the inside of the can. Prior to replacing the three fixings located in the valve block underside, apply a small amount of Loctite 243 to each screw thread. Ensure the three fixings are fully secure.
- Pressure test as described in Section 5.3.

5.5 Mesh Panel Removal

Some damage to the mesh panels such as indentation is acceptable and will not cause deterioration in burner performance. However, if the panels have been damaged in such a way that they may cause cuts or other injury to personnel, they must be replaced.

To remove the mesh panels, refer to Section 5.4.

5.6 Piezo Igniter Assembly Removal

To remove the Piezo Igniter Assembly, refer to Figure 5 and proceed as follows:

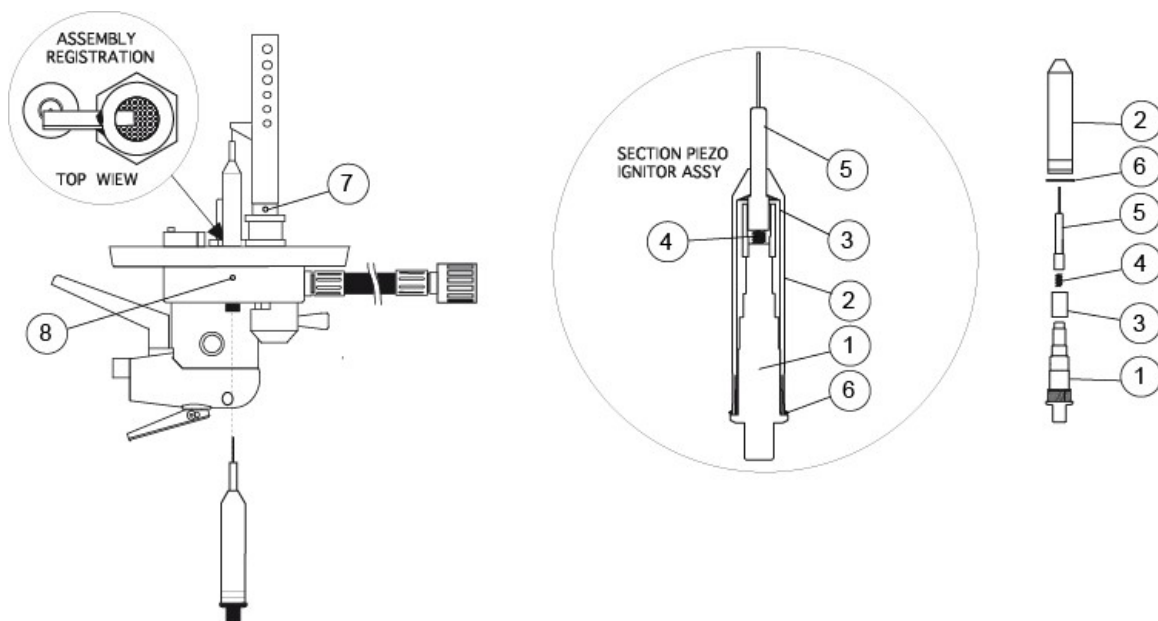

ITEM	DESCRIPTION	DWG / PART NUMBER
1	PIEZO IGNITER UNIT	CR-PPD-0061
2	PIEZO IGNITER SUPPORT TUBE	CR-PPD-0057
3	PIEZO IGNITER INSULATOR	CR-PPD-0060
4	PIEZO IGNITER SPRING	CR-PPD-0059

5	PIEZO IGNITER CERAMIC ELECTRODE	CR-PPD-0058
6	NB 2050 NBR 70 SHORE O-R SEAL	CR-PP-0324
7	M6x6 ST STL HEX DRIVE DIN 914 GRUB SCREW	CR-N-0040
8	M6x8 ST STL HEX DRIVE DIN 914 GRUB SCREW	CR-PP-0022

Figure 5

- Ensure that the burner is completely vented of fuel.
- Using a 3mm Allen key, loosen but do not remove the grub screw (item 8).
- Withdraw the igniter assembly from the underside of the valve block.
- Unscrew and remove the piezo igniter (item 1) from the body (item 2). Carefully withdraw the igniter.
- Check the condition of the "O" seal (item 6) fitted on the exterior surface of the igniter body and underneath the piezo flange. Replace the seal if damaged. Note that the seal is fitted to prevent water formed inside the burner from dripping down past the igniter assembly and a damaged seal will not cause deterioration in burner performance.
- Withdraw the insulator, spring and electrode (items 3,4 and 5 respectively) from the body. Check the condition of each of the components. If the electrode ceramic is cracked, it must be replaced.
- Replacement is generally the reverse procedure of removal. Prior to fitting the "O" seal, apply a thin smear of Krytox 125 grease to the seal. Take care not to over-tighten the grub screw (item 8) as this might cause damage to the aluminium thread in the valve block.
- Having re-fitted the igniter, operate the igniter and check for a good spark between the electrode tip and the tag on the pilot light assembly. Adjust the gap if necessary to improve the spark strength. The spark should be "strong" and blue in colour.

5.7 Pilot Light Assembly Removal and Disassembly

The following instructions assume that the burner is already removed from the burner frame but otherwise fully assembled. To remove the pilot light assembly, refer to Figure 6 and proceed as follows:

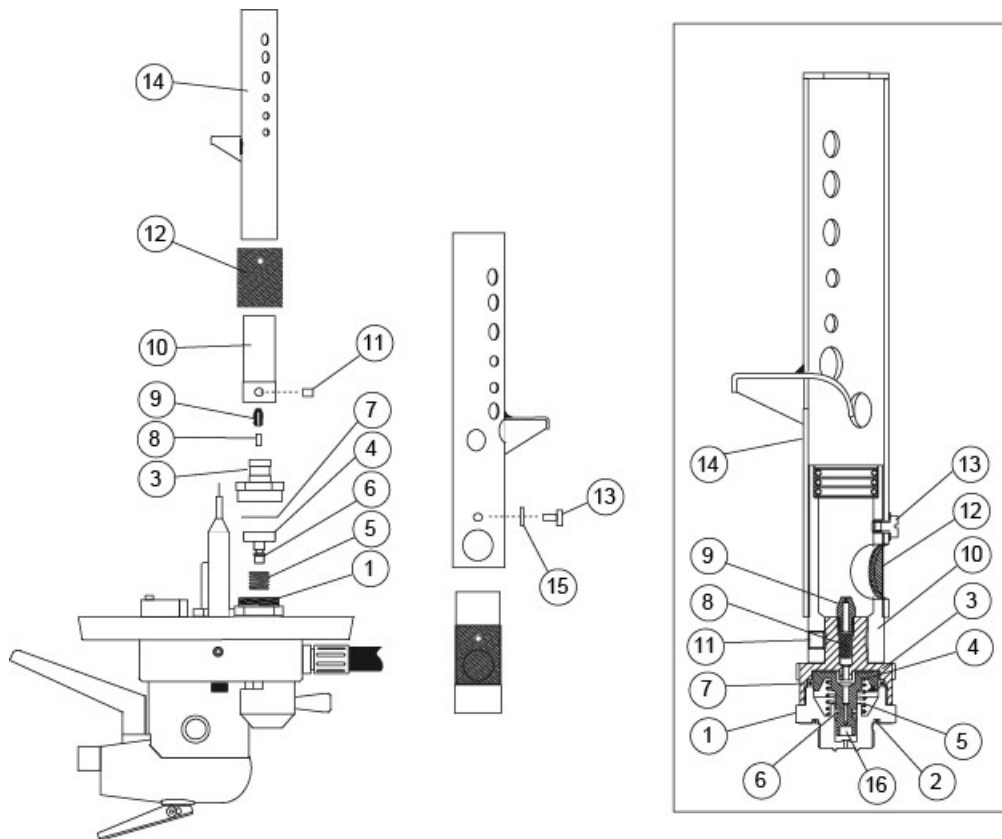

ITEM	DESCRIPTION	DWG / PART NUMBER
------	-------------	-------------------

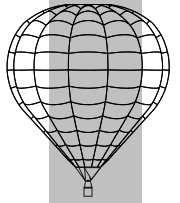

1	PILOT LIGHT REGULATOR LOWER BODY	CR-PPD-0043
2	NB 2087 NBR 70 SHORE O-R SEAL	CR-PP-0326
3	PILOT LIGHT REGULATOR UPPER BODY	CR-PPD-0039
4	PILOT LIGHT REGULATOR PISTON	CR-PPD-0040
5	PILOT LIGHT REGULATOR SPRING	CR-PPD-0091
6	FPM 2015 VITON 75 SHORE O-R SEAL	CR-PP-0311
7	FPM 2081 VITON 75 SHORE O-R SEAL	CR-PP-0312
8	FUEL FILTER	CR-PPD-0038
9	PILOT LIGHT FLAME JET	CR-PPD-0037
10	PILOT LIGHT FLAME LOWER TUBE	CR-PPD-0035
11	M6x6 ST STL HEX DRIVE DIN 914 GRUB SCREW	CR-N-0040
12	PILOT LIGHT FLAME TUBE GAUZE	CR-PPD-0036
13	M4x5 ST STL FLAT DRIVE DIN 84 SCREW	CR-PP-0031
14	PILOT LIGHT FLAME UPPER TUBE RH	CR-PPD-D032
15	M4 ST STL DIN 125 FLAT WASHER	CR-PP-0201
16	PILOT LIGHT REGULATOR STEM PISTON SEAL	CR-PPD-0041

Figure 6

- Ensure that the burner is completely vented of fuel.
- Using a 4mm Allen key, undo and remove the four fixings located in the underside of the valve block. Note that upon removal of the fixings, the valve block is no longer supported and is free to be withdrawn. Make sure therefore that the valve block is supported before removing the fixings.
- Carefully separate the can and coil, as one assembly, from the valve block.
- Using a 3mm Allen key, undo and remove the screw (item 11) securing the complete assembly to the regulator body.
- Carefully withdraw the pilot light assembly from the regulator.
- To further strip down the pilot light assembly, use a flat blade screwdriver and remove the screw and washer (item 13, 15) securing the upper tube to the lower tube. Carefully separate the upper and lower tubes taking care not to damage the mesh filter (item 12) fitted between the two components.
- Check the condition of the mesh filter. Remove any large contaminants using a blast of air. Oily deposits may be removed by soaking the filter in a suitable solvent.
- Re-assembly is generally the reverse procedure of disassembly. When fitting the filter (item 12), make sure that the small hole in the filter is aligned with the hole in the lower tube. Make sure the filter is flat against the tube and free from wrinkles. Take care to prevent the filter "snagging" between the upper and lower tubes during re-assembly.
- Position the assembly on the regulator so that the igniter electrode aligns with the tag on the side of the upper tube. Adjust the position of the upper tube to obtain the best spark between the electrode and the tag.

5.8 Regulator Removal and Disassembly

To remove the pilot regulator assemblies refer to Figure 6 and proceed as follows:

- Ensure that the burner is completely vented of fuel.
- Using a 4mm Allen key, undo and remove the three fixings located in the underside of the valve block. Note that upon removal of the four fixings, the valve block is no longer supported and is free to be withdrawn. Make sure therefore that the valve block is supported before removing the fixings.
- Remove the pilot light assembly as described in Section 5.7.
- Remove the igniter assembly as described in Section 5.6.
- Hold the valve block securely, preferably in soft vice jaws.
- Using a 30mm AF open-ended spanner, undo and remove the lower body (item 1) from the valve block. Take care to protect the "O" seal (item 2) mounted on the underside of the body.
- Check inside the regulator-mounting hole in the valve block for any dirt. Clean if necessary.
- Carefully place the lower body hexagon in soft vice jaws. Using a 30mm open-ended spanner, undo and remove the upper body (item 3). Take care when removing the upper body, as this will expose the piston, spring and "O" seal.
- Remove the piston, spring and "O" seal (items 4, 5 and 7 respectively).
- Using a suitable soft-ended instrument, remove the "O" seal (item 6) from the piston stem. Take care not to scratch the piston surfaces.

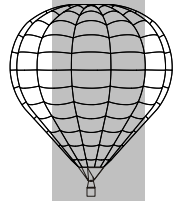

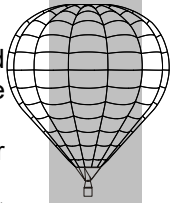

- Remove the "O" seal (item 2) from the underside of the lower body.
- Check the condition of the three "O" seals and replace if necessary.
- Check the condition of the seal fitted in the end of the piston stem. If the seal is damaged or has deteriorated, then the entire piston must be replaced, as the seal cannot be removed independently.
- Using a 6.5mm open-ended spanner, undo and remove the jet (item 9). Remove the filter (item 8).
- Check that the small hole in the jet is clear. Remove any contaminants from inside the jet if necessary.
- Check that the filter is clean. If the filter is considered to be dirty, it must be replaced. Do not attempt to clean the filter as this may result in permanent damage.
- Check the condition of all the surfaces on the regulator bodies and piston where the seals are in contact. If significant scratches are noted, the part must be replaced. As a guide, scratches, which may be felt with a fingernail, are significant.
- Check the condition of the valve block surface where the "O" seal (item 2) makes contact. If the surface is damaged, contact Ultramagic for further instructions.
- Check that the seal sits inside the groove correctly. Poorly fitting seals must be replaced.
- Check the inside of the regulator bodies for the build up of oil. Oily deposits must be removed using a soft cloth and a gentle solvent if necessary. Make sure that the seals are not exposed to the solvent. Ensure that all traces of the solvent are removed before re-assembly.
- Replacement is generally the reverse procedure of removal. Prior to replacing the "O" seals, apply a thin smear of Krytox 125 grease to the seals and to the mating surfaces. Apply a thin smear of the same grease to the seal fitted in the end of the piston stem. Remember to fit the filter before fitting the jet. To aid assembly, fit the lower body and seal to the valve block before assembling the piston and upper body.
- Upon replacement of the regulator assembly, connect the block to a compressed air supply not exceeding 6.8bar (100 psi). Apply leak detector fluid to all the joints and open the pilot valve. Check for any leaks. If any leaks are detected they must be corrected prior to return to service.

Note that excessive accumulation of oil inside the regulator can cause the pilot light flame to deteriorate significantly. The rate at which oil accumulates depends greatly upon the quality of the fuel. Over time, if the oil is not removed, a sticky residue can accumulate preventing the piston from moving correctly and blocking the small filter. This may cause pilot light failure. It is important therefore to ensure that the regulator is kept clean.

5.9 Fuel Filter Removal and Disassembly

The filter may be removed in one of two ways. The first requires the use of a very long flat bladed screwdriver and accessing the filter from the top of the coil. However, depending upon the tools available and the conditions at the time it may be considered more practicable to disassemble the valve block from the can first. The following instructions assume the latter method is adopted.

To remove the fuel filter assembly, refer to Figure 7 and proceed as follows:

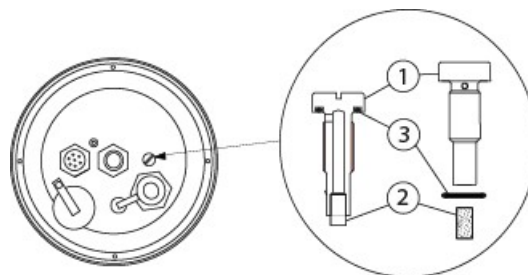

ITEM	DESCRIPTION	DWG / PART NUMBER
1	PILOT LIGHT INLET FILTER HOUSING	CR-PPD-0065
2	FUEL FILTER	CR-PPD-0038

3	NB 108 NBR 70 SHORE O-R SEAL	CR-PP-0321
---	------------------------------	------------

Figure 7

- Ensure that the burner is completely vented of fuel prior to removal of the filter assembly.
- Using a 4mm Allen key, undo and remove the three fixings located in the underside of the valve block. Note that upon removal of the fixings, the valve block is no longer supported and is free to be withdrawn. Make sure therefore that the valve block is supported before removing the fixings.
- Carefully separate the can and coil, as one assembly, from the valve block. It was received on
- Using a large flat bladed screwdriver, undo and remove the filter body (item 1) from the valve block. Make sure that the screwdriver is the correct size for the job as use of the incorrect size may cause damage to the slot in the screw head.
- Carefully extract the filter (item 2) from the body (item 1). Check the condition of the filter and replace if considered necessary.
- Check the condition of the "O" seal (item 3) fitted on the underside of the body head. Damaged seals must be replaced.
- Check the condition of the "O" seal groove in the underside of the body head. If significant scratches exist, the body must be replaced.
- Inspect the inside of the body to ensure that there are no blockages. Clean using a blast of air if necessary.
- Replacement is generally the reverse procedure of removal. Prior to replacing the "O" seal, apply a thin smear of Krytox 125 grease to the seal. Take care to ensure that excessive grease is not used and that the small hole adjacent to the seal does not become blocked with grease.
- Upon replacement of the filter assembly, connect the block to a compressed air supply not exceeding 6,8bar (100 psi). Apply leak detector fluid to all the joints. Check for any leaks. If any leaks are detected they must be corrected prior to return to service.

5.10 Pressure Gauge Removal

To remove the pressure gauges, refer to Figure 8 and proceed as follows:

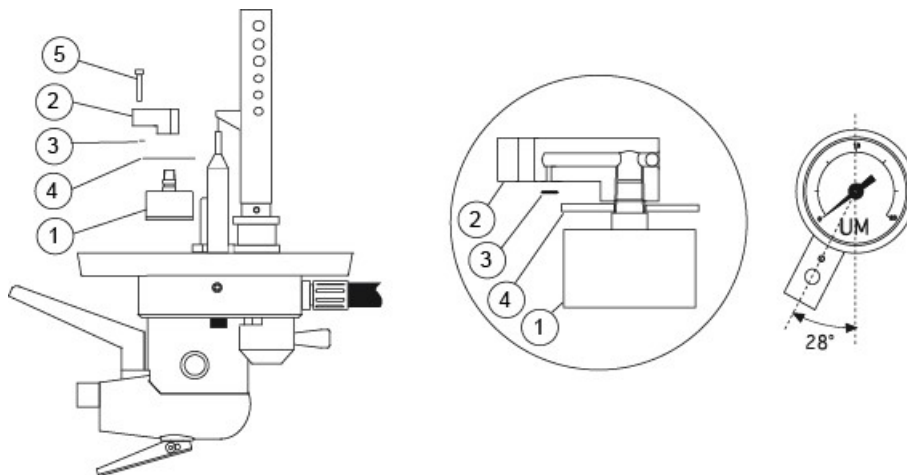

ITEM	DESCRIPTION	DWG / PART NUMBER
1	PRESSURE GAUGE	CR-PPD-0062
2	PRESSURE GAUGE CONNECTION	CR-PPD-0063
3	NB 2010 NBR 70 SHORE O-R SEAL	CR-PP-0322
4	PRESSURE GAUGE BODY SEAL	CR-PPD-0064
5	M5x25 ST STL HEX DRIVE DIN 912 SCREW	FA-FE-0840

Figure 8

- Ensure that the burner is completely vented of fuel.
- Using a 4mm Allen key, undo and remove the three fixings located in the underside of the valve block. Note that upon removal of the four fixings, the valve block is no longer

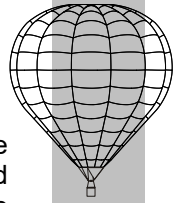

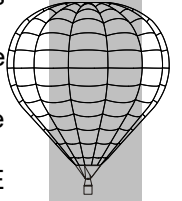

- supported and is free to be withdrawn. Make sure therefore that the valve block is supported before removing the fixings.
- Using a 4mm Allen key, undo and remove the screw fixing (item 5) securing the pressure gauge connection (item 2) to the valve block.
 - Carefully withdraw the pressure gauge connection and pressure gauge as a complete assembly from the valve block. Take care not to loose the small "O" seal (item 3).
 - Unscrew the pressure gauge from the gauge connection. Clean off all traces of PTFE tape from the gauge thread
 - Remove the small "O" seal (item 3) fitted in the groove between the gauge connection (item 2) and the aluminium block. Check the condition of the seal. If any deterioration of the seal is detected, it must be replaced.
 - Check the condition of the "O" seal groove and the seal bore in the gauge connection. If there is any damage to the seal mating surfaces, the gauge connection must be replaced.
 - Check the condition of the gauge body seal (item 4). The seal is designed to prevent the passage of water from inside the burner through the valve block. Minor deterioration of the seal is therefore not detrimental to burner performance or safety. However, it is recommended that the seal be replaced if damage or deterioration is found.
 - Replacement is generally the reverse procedure of removal. Prior to fitting the seals, apply a thin smear of Krytox 125 grease to the seals. Prior to fitting the screw (item 5) apply a small quantity of Loctite 243 to the screw thread. Check for the correct orientation of the gauge inside the valve block.
 - Upon re-assembly, connect the block to a compressed air supply not exceeding 6,8bar (100 psi). Apply leak detector fluid to all the joints. Check for any leaks. If any leaks are detected they must be corrected prior to return to service.

5.11 Liquid Jet Removal

To remove the liquid jets, refer to Figure 3 and proceed as follows:

- Ensure the burner is completely vented of fuel.
- Using a 4mm Allen key, undo and remove the four fixings located in the underside of the valve block. Note that upon removal of the fixings, the valve block is no longer supported and is free to be withdrawn. Make sure therefore that the valve block is supported before removing the fixings.
- Access to the liquid jets may be improved by first removing the pressure gauge (see section 5.10).
- Using a 27mm AF spanner, undo and remove the liquid jet (item 13).
- Remove the "O" seal (item 14) from the underside of the jet lower flange where it mates with the valve block. Check the condition of the seal. If any deterioration of the seal is detected, it must be replaced.
- Check the condition of the "O" seal groove. If there is any damage to the seal mating surfaces, the jet must be replaced.
- Check the condition of the valve block surface where the seal mates. The surface must be free from damage such as significant scratches. As a guide, scratches detectable with a fingernail are considered significant. If significant damage is detected, contact Ultramagic for further advice.
- Check inside the jet-mounting hole in the valve block for any dirt. Clean if necessary.
- Replacement is generally the reverse procedure of removal. Prior to replacing the seal, apply a thin smear of Krytox 125 grease to the seal.
- Upon re-assembly, connect the block to a compressed air supply not exceeding 6,8bar (100 psi). Apply leak detector fluid to all the joints. Check for any leaks. If any leaks are detected they must be corrected prior to return to service.

5.12 Main Valve Sleeve Removal

To remove the main valve sleeves, refer to Figure 3 and proceed as follows:

- Ensure the burner is completely vented of fuel.
- Using a 4mm Allen key, undo and remove the four fixings located in the underside of the valve block. Note that upon removal of the fixings, the valve block is no longer supported

and is free to be withdrawn. Make sure therefore that the valve block is supported before removing the fixings.

- Access to the main valve sleeves will be greatly improved by first removing the pressure gauge (section 5.10) and the liquid fire jet (section 5.11).
- Using a 27mm AF open-ended spanner, undo and remove the valve sleeve.
- Remove the "O" seal (item 14) from the underside of the sleeve lower flange where it mates with the valve block. Check the condition of the seal. If any deterioration of the seal is detected, it must be replaced.
- Check the condition of the "O" seal groove. If there is any damage to the seal mating surfaces, the sleeve must be replaced.
- Check the condition of the valve block surface where the seal mates. The surface must be free from damage such as significant scratches. As a guide, scratches detectable with a fingernail are considered significant. If significant damage is detected, contact Ultramagic for further advice.
- Check inside the sleeve-mounting hole in the valve block for any dirt. Clean if necessary.
- Replacement is generally the reverse procedure of removal. Prior to replacing the seal, apply a thin smear of Krytox 125 grease to the seal.
- Upon re-assembly, connect the block to a compressed air supply not exceeding 6,8bar (100 psi). Apply leak detector fluid to all the joints. Check for any leaks. If any leaks are detected they must be corrected prior to return to service.

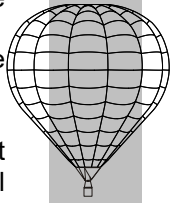

5.13 Removal of Fuel Hose

To replace a fuel hose, refer to Figures 1 and 9 and proceed as follows:

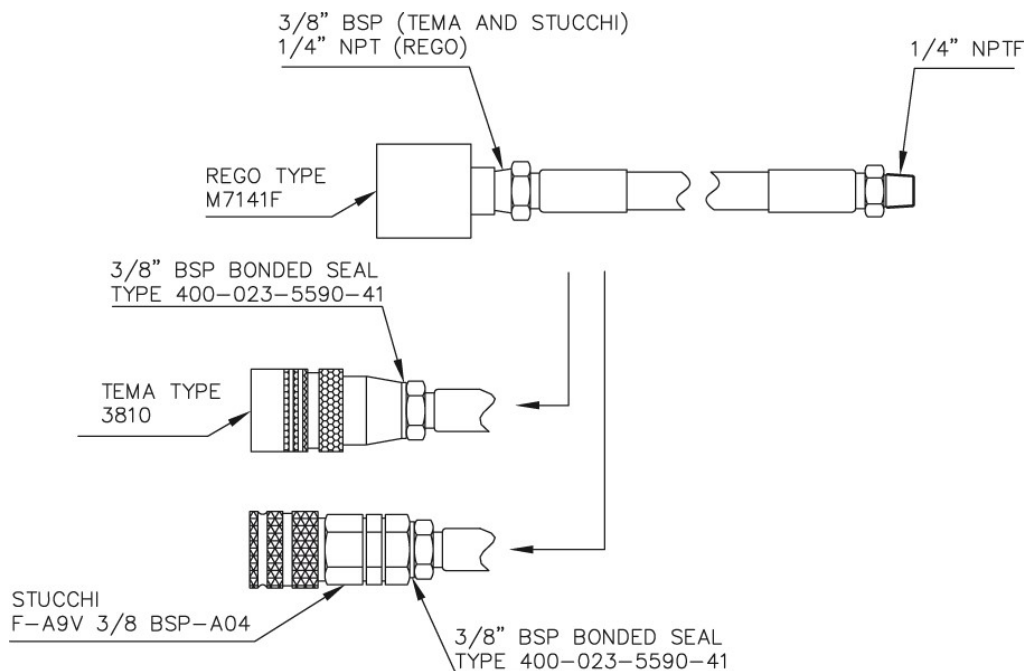
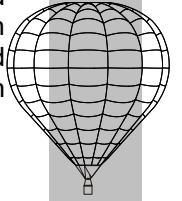

Figure 9

- Ensure that the burner is completely vented of fuel and that the hose is disconnected from the fuel cylinder.
- Using a 15mm open-ended spanner, undo the hose from the valve block.
- Remove all PTFE tape from the screw thread.
- Replace the hose with a new one if necessary. When ordering a replacement hose, refer to Figure 10 and specify the length and end fitting required. Cover the thread with a minimum of three turns of PTFE tape. Wind the tape on to the thread in the correct direction so that it does not tend to undo whilst it is being screwed in to the valve block. Take care when re-fitting the hose to prevent damage to the thread in the aluminium valve block.
- Ensure that the hose to valve block joint is tight.

- Pressure test the hose by connecting the fuel connector to a 7 Bar (100 psi) compressed air supply. Check the joint between the fuel connector and the hose and the joint between the hose and the fuel inlet post. The joints may be checked using leak detection fluid and watching for bubbles when the air pressure is applied. If any bubbles are observed, then there is a leak, which must be rectified before further burner use.



5.14 Liquid Valve Handles

To remove the liquid valve handles, refer to Figure 10 and proceed as follows:

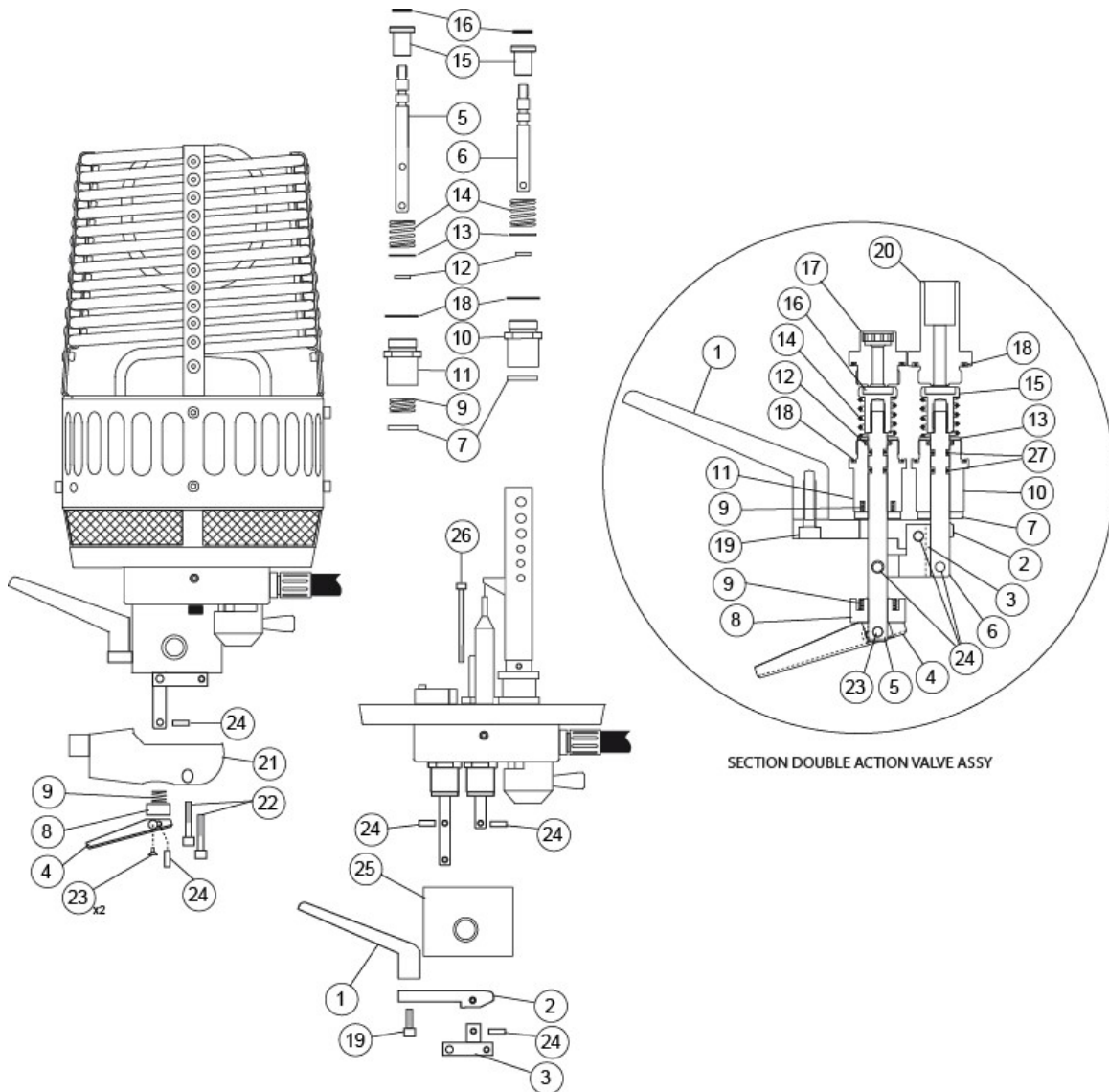

ITEM	DESCRIPTION	DWG / PART NUMBER
1	BLAST VALVE HANDLE RH (ROUGH)	CR-PPD-D070
2	DOUBLE ACTION VALVE CAM	CR-PPD-0076
3	CAM / STEM CONNECTION	CR-PPD-0077
4	POWERPLUS DOUBLE LIQUID HANDLE BLUE	CR-PPD-B069
5	LIQUID VALVE STEM	CR-PPD-L078
6	BLAST VALVE STEM	CR-PPD-P078
7	BLAST / LIQUID VALVE ANTIFRICTION WASHER	CR-PPD-0080
8	LIQUID HANDLE COMPENSED ANTIFRICTION WASHER	CR-PPD-0083
9	LIQUID HANDLE SPRING	CR-PPD-0094
10	BLAST VALVE CENTRE BODY	CR-PPD-P079
11	LIQUID VALVE CENTRE BODY	CR-PPD-L079
12	APS MAA-000762-01-01-1 ENERGIZED SEAL	CR-PP-0301
13	VALVE PTFE SEAL RETAINING WASHER	CR-PPD-0088
14	BLAST / LIQUID VALVE SPRING	CR-PPD-0090
15	VALVE STEM SHUTTER	CR-PPD-0045
16	VALVE SHUTTER SEAL PAD	CR-PPD-0044

17	LIQUID CONNECTION JET	CR-PPD-0075
18	NB 2087 NBR 70 SHORE O-R SEAL	CR-PP-0326
19	M5x20 ST STL HEX DRIVE DIN 912 SCREW	MA-FE-0170
20	BLAST VALVE SLEEVE	CR-PPD-0074
21	POWERPLUS DOUBLE BAR END CAP	CR-PPD-0072
22	M5x30 ST STL HEX DRIVE DIN 912 SCREW	CR-PP-0016
23	M3x5 ST STL HEX DRIVE DIN 7991 SCREW	CR-PP-0001
24	CONNECTION STEM MOVEMENT PIN	CR-PPD-0081
25	VALVE EXTERNAL BODY RH	CR-PPD-D071
26	M5x50 ST STL HEX DRIVE DIN 912 SCREW	CR-PP-0017
27	NB 2018 NBR 70 SHORE O-R SEAL	CR-PP-0323

Figure 10

- Ensure that the burner is completely vented of fuel.
- Using a 2mm Allen key, undo the two small screws (item 23) located in the side of the handle body (item 4), and remove the locking pin (item 24). Remove the handle.
- Remove the handle washer (item 8) and the compression spring (item 9).
- Re-assembly is generally the reverse procedure to disassembly. In order to prevent the possibility of the valve freezing, all moving parts must be lubricated with plenty of Molycote graphite grease.
- Upon completion, check the function of the liquid valve. Make sure that the valve creates a seal when in the off position and allows the flow of fuel when activated.

5.15 Burner Handle Removal

5.15.1 Bar Handle Removal

To remove the bar handle, refer to Figure 11 and proceed as follows:

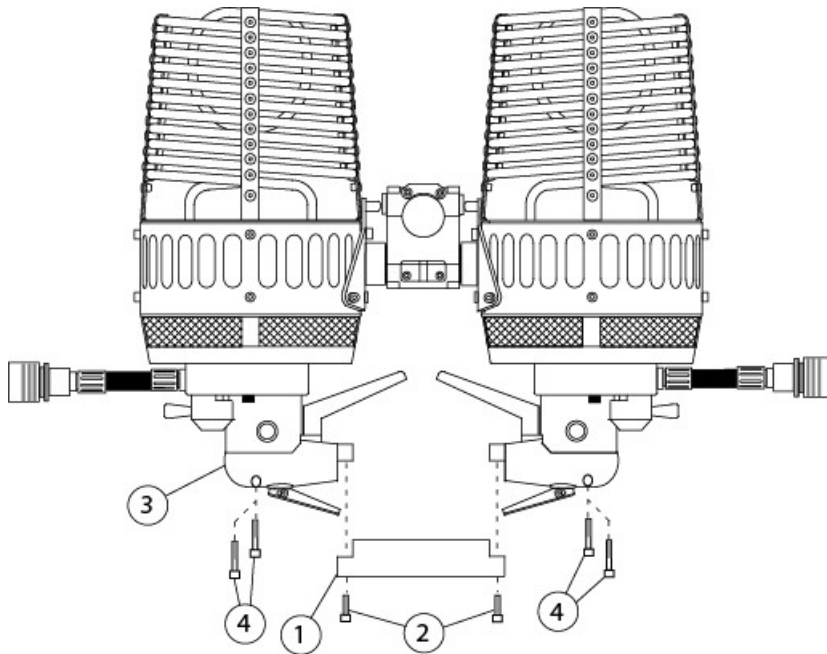

ITEM	DESCRIPTION	DWG / PART NUMBER
1	DOUBLE BURNER BAR HANDLE CONNECTION	CR-PPD-0073
2	M5x20 ST STL HEX DRIVE DIN 912 SCREW	MA-FE-0170
3	POWERPLUS DOUBLE BURNER BAR END CAP	CR-PPD-0072
4	M5x30 ST STL HEX DRIVE DIN 912 SCREW	CR-PP-0016

Figure 11

- Using a 4mm Allen key, undo and remove the two cap head screws (item 2) (one at each end) securing the bar handle (item 1) to the handle end caps (item 3). Withdraw the bar handle.

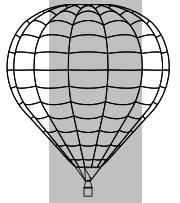

- Replacement is generally the reverse procedure to removal. Prior to re-fitting the two screws, apply a small quantity of Loctite 243 to the screw threads.

5.15.2 Handle End Cap Removal

To remove the handle end cap, refer to Figure 11 and proceed as follows:

- Remove the bar handle as described in Section 5.15.1.
- Remove the liquid valve handle as described in section 5.14.
- Using a 4mm Allen key, undo and remove the screw (item 4) securing the end cap (item 3).
- Withdraw the end cap.
- Replacement is generally the reverse procedure to removal. Prior to re-fitting the screw (item 4) apply a small quantity of Loctite 243 to the screw threads.

5.16 Double Action Mechanism Removal

The main and liquid burner valves are linked via a special mechanism. Movement of the main burner valve handle to the first (intermediate) position will open the associated main valve. Further movement of the handle will cause the associated liquid valve to open simultaneously thus enabling approximately double burner power output through single hand activation. Thus the main and liquid valve activation mechanism may be thought of as common to both valves and the mechanism must be disassembled before either of the valves may be removed.

To remove the double action mechanism, refer to Figure 10 and proceed as follows:

- Ensure that the burner is completely vented of fuel.
- Remove the bar handle as described in Section 5.15.1.
- Remove the liquid valve handle as described in Section 5.14.
- Remove the handle end cap as described in section 5.15.2.
- Remove the three pivot pins (item 24) securing the blast valve cam (item 2), the connection cam/stem (item 3), the blast valve stem (item 6) and the liquid valve stem (item 5).
- Do not disassemble the handle (item 1) from the cam (item 2) if it is not considered necessary. To disassemble the handle and cam, remove the screw from the underside of the cam using a 4mm Allen key.
- The components used in the mechanism are generally robust and are not subject to significant wear. Component failure or deterioration is therefore unlikely. However, check the components for significant wear or any other problem, which might cause the mechanism to fail in the future. If any significant deterioration is detected, replace the part.
- Re-assembly is generally the reverse procedure of disassembly. Prior to re-assembling the handle (item 1) to the cam (item 2), apply a small quantity of Loctite 243 to the screw thread. **Note: It is important to ensure that upon re-assembly, all moving joints are well lubricated with Molycote graphite grease. The grease prevents moisture settling on the joints and thus prevents any possibility of the joints freezing together during operation.**

5.17 External Valve Body Removal

The external valve body is fitted on the underside of the main valve block and encloses the main and liquid valve bonnets. In order to gain access to the main and liquid valves, the external valve body must be removed. To remove the external valve body, refer to Figure 10 and proceed as follows:

- Ensure that the burner is completely vented of fuel.
- Removal of the external valve body will require access to a single fixing screw fitted on the upper side of the main valve block. The screw may be accessed either by using a 4mm Allen key attached to a long extension or by first removing the can and coil. The best approach to screw removal will depend upon the tools available and the conditions

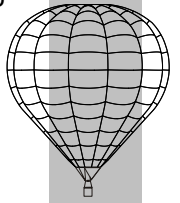

at the time. The following procedure assumes that the valve block is separated from the can and coil.

- Using a 4mm Allen key, undo and remove the four fixings located in the underside of the valve block. Note that upon removal of the four fixings, the valve block is no longer supported and is free to be withdrawn. Make sure therefore that the valve block is supported before removing the fixings.
- Remove the bar handle as detailed in Section 5.15.1
- Remove the liquid valve handle as detailed in Section 5.14
- Remove the handle end cap as detailed in Section 5.15.2.
- Remove the double-action mechanism as detailed in section 5.16.
- Using a 4mm Allen key, undo and remove the single fixing (item 26) situated on the upper side of the valve block.
- Remove the external valve body.
- Replacement is generally the reverse procedure of removal. Prior to replacing the fixing screw (item 26), apply a small quantity of Loctite 243 to the screw threads.

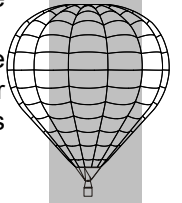

5.18 Pilot Valve Removal and Disassembly

To remove the pilot light valve, refer to Figure 12 and proceed as follows:

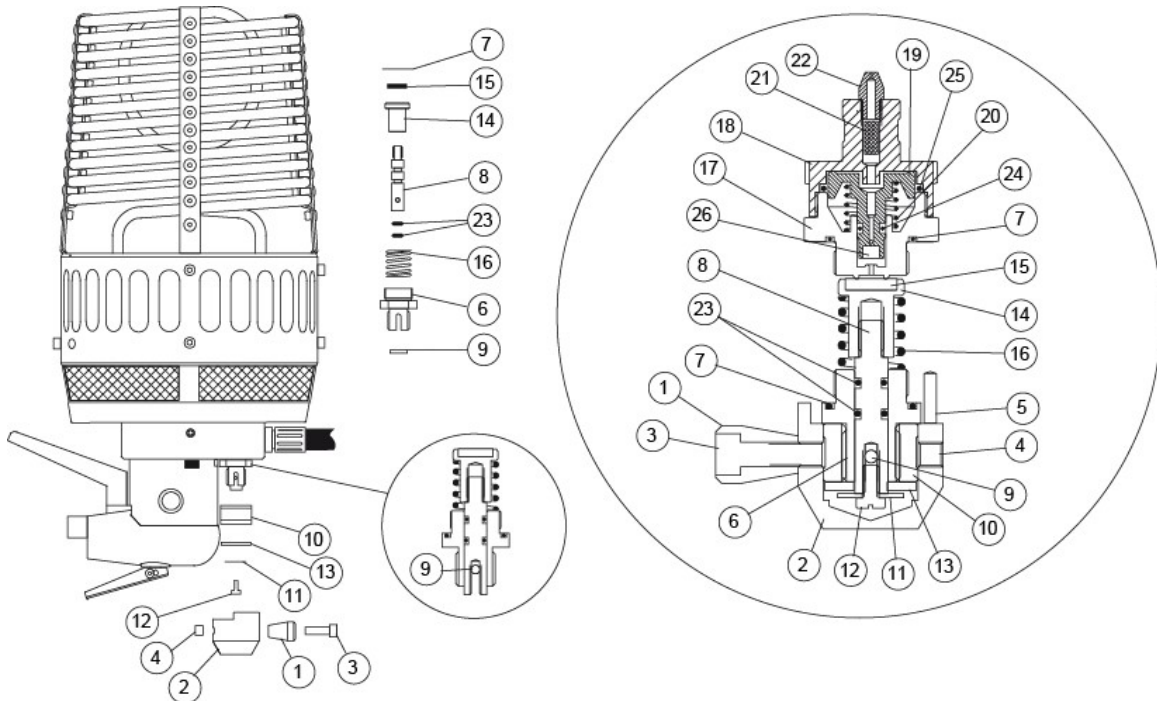

ITEM	DESCRIPTION	DWG / PART NUMBER
1	PILOT LIGHT KNOB HANDLE	CR-PPD-V055
2	PILOT LIGHT KNOB BODY	CR-PPD-V054
3	M6x20 ST STL HEX DRIVE DIN 912 SCREW	CR-C-0250
4	M6x6 ST STL HEX DRIVE DIN 914 GRUB SCREW	CR-N-0040
5	ANTIROTATION PIN	CR-PPD-0082
6	PILOT LIGHT VALVE BONNET	CR-PPD-0049
7	NB 2087 NBR 70 SHORE O-R SEAL	CR-PP-0326
8	PILOT LIGHT VALVE STEM	CR-PPD-0046
9	STEM ANTIROTATION PIN	CR-PPD-0082
10	PILOT VALVE OPENING RING	CR-PPD-0050
11	PILOT VALVE STEM STOP WASHER	CR-PPD-0087
12	M4x8 ST STL FLAT DRIVE DIN 84 SCREW	CR-PP-0032
13	PILOT VALVE ANTI-FRICTION WASHER	CR-PPD-0084
14	VALVE STEM SHUTTER	CR-PPD-0045
15	VALVE SHUTTER SEAL PAD	CR-PPD-0044
16	PILOT VALVE SPRING	CR-PPD-0090
17	PILOT LIGHT REGULATOR LOWER BODY	CR-PPD-0043
18	PILOT LIGHT REGULATOR UPPER BODY	CR-PPD-0039
19	PILOT LIGHT REGULATOR PISTON	CR-PPD-0040
20	PILOT LIGHT REGULATOR SPRING	CR-PPD-0091
21	FUEL FILTER	CR-PPD-0038
22	PILOT LIGHT FLAME JET	CR-PPD-0037

23	NB 2018 NBR 70 SHORE O-R SEAL	CR-PPD-0323
24	FPM 2015 VITON 75 SHORE O-R SEAL	CR-PP-0311
25	FPM 2081 VITON 75 SHORE O-R SEAL	CR-PP-0312
26	PILOT LIGHT REGULATOR STEM PISTON SEAL	CR-PPD-0041

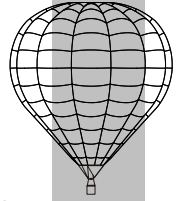
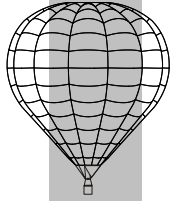

Figure 12

- Ensure the burner is completely vented of fuel.
- Make sure the valve is in the closed position. Make a note of the position of the knob and knob handle. This will greatly assist when re-assembling.
- Using a 3mm Allen key, undo and loosen the grub screw (item 4) located in the side of the pilot valve knob (item 2). Do not fully remove the screw. Carefully withdraw the knob.
- Using a flat-bladed screwdriver, undo and remove the fixing screw (item 12) located in the end of the valve. Remove the plain washer (item 11) and the anti-friction washer (item 13).
- Unscrew and remove the threaded ring (item 10).
- Using a suitable probe, push out and remove the anti-rotation pin (item 9).
- Using a 26mm AF open-ended spanner, undo and remove the valve bonnet (item 6) from the main valve block.
- Extract the valve stem and shutter assembly (items 8 and 14) and the valve spring (item 16) from the bonnet (item 6).
- The valve stem is screwed in to the shutter and locked with a screw thread adhesive. It is recommended therefore that no attempt be made to separate the shutter from the stem, as it is likely that surfaces will be damaged in the process.
- The seal (item 15) is permanently fixed in to the shutter. Do not attempt to remove it.
- Using a suitable soft-ended probe, carefully remove the "O" seals (item 23) from the valve stem.
- Remove the large "O" seal (item 7) from the underside of the valve bonnet collar where it mates with the valve block.
- Check the condition of all "O" seals. Damaged seals must be replaced.
- Check the condition of the shutter seal. The surface should be smooth and free from any damage. If the seal is considered to be defective, replace the complete shutter and stem assembly.
- Check the condition of all the "O" seal grooves. If any significant damage such as scratching to the groove surfaces is detected, then the component must be replaced. As a guide, scratches detectable with a fingernail are considered significant.
- Check the condition of the bore inside the valve bonnet. If any significant scratches (particularly scratches running along the length of the bore) are detected, the bonnet must be replaced.
- Check the condition of the valve block lower surface where it mates with the large "O" seal on the underside of the bonnet collar. If any significant damage or deterioration is detected, contact Ultramagic for further advice.
- Re-assembly is generally the reverse procedure to disassembly. Remember to fit the anti-rotation pin (item 9). Prior to re-assembly, apply a thin smear of Krytox 125 grease to all the "O" seals. Apply a small quantity of Loctite 243 to the screw thread (item 12) prior to fitting. In order to prevent the possibility of the valve freezing, all moving parts must be lubricated with plenty of Molycote graphite grease, mainly at the pin (item 9) groove.
- The valve design is such that the position of the ring (item 10) must be set to the correct position. If the ring is not set correctly, the valve may fail to open or close correctly. To set the ring position, fully assemble the valve but do not fit the knob and handle (items 2 and 1 respectively). Carefully unscrew the ring until the anti-friction washer (item 13) just begins to push against the plain washer (item 11). Re-assemble the knob (item 2) and set it in the closed position. Secure the knob by tightening the grub screw (item 4). To assist with the process of correctly setting the knob position, it may be useful to connect the burner to a compressed air supply. Set the knob position by checking for the sound of air exiting from the pilot light as the knob is rotated between the on and off positions.
- Upon re-assembly, connect the block to a compressed air supply not exceeding 6,8bar (100 psi). Apply leak detector fluid to all the joints. Check for any leaks. If any leaks are detected they must be corrected prior to return to service.
- Check for the correct function of the pilot light valve by operating it normally. Ensure that the valve opens and closes correctly. If it is found that the valve does not function correctly, the problem must be resolved prior to returning the burner to service.



5.19 Liquid Valve Removal and Disassembly

To remove and disassemble the liquid valves, refer to Figure 10 and proceed as follows:

- Ensure that the burner is completely vented of fuel.
- Remove the bar handle as detailed in section 5.15.1.
- Remove the liquid valve handle as detailed in section 5.14.
- Remove handle end cap as detailed in section 5.15.2
- Remove the double action mechanism as detailed in section 5.16.
- Remove the external valve body as detailed in section 5.17.
- Remove antifriction washer (item 7) and spring (item9).
- Using a 27 mm AF open-ended spanner, undo and remove the valve bonnet (item 10) from the main valve block.
- Extract the valve stem and shutter assembly (items 15 and 14) and the valve spring (item 13) from the bonnet (item 11).
- The valve stem is screwed in to the shutter and locked with a screw thread adhesive. It is recommended therefore that no attempt be made to separate the shutter from the stem, as it is likely that surfaces will be damaged in the process.
- The seal (item 16) is permanently fixed in to the shutter. Do not attempt to remove it.
- Remove the seal-retaining washer (item 13).
- Carefully remove the energised seal (item 12) from the bore inside the valve bonnet.
- Using a suitable soft-ended probe, carefully remove the "O" seals (item 27) from the valve stem (item 5).
- Remove the large "O" seal (item 28) from the underside of the valve bonnet collar where it mates with the valve block.
- Check the condition of all "O" seals. Damaged seals must be replaced.
- Check the condition of the shutter seal. The surface should be smooth and free from any damage. If the seal is considered to be defective, replace the complete shutter and stem assembly.
- Check the condition of the PTFE energised seal (item 12). If the seal is defective, it must be replaced.
- Check the condition of all the "O" seal grooves. If any significant damage such as scratching to the groove surfaces is detected, then the component must be replaced. As a guide, scratches detectable with a fingernail are considered significant.
- Check the condition of the bores inside the valve bonnet. If any significant scratches (particularly scratches running along the length of the bore) are detected, the bonnet must be replaced.
- Check the condition of the valve block lower surface where it mates with the large "O" seal on the underside of the bonnet collar. If any significant damage or deterioration is detected, contact Ultramagic for further advice.
- Re-assembly is generally the reverse procedure to disassembly. Prior to re-assembly, apply a thin smear of Krytox 125 grease to all the "O" seals and Molycote graphite grease to the antifriction washer (item 7).
- Prior to fitting the external valve body, connect the block to a compressed air supply not exceeding 6,8bar (100 psi). Apply leak detector fluid to all the joints of all valves removed. Check for any leaks. If any leaks are detected they must be corrected prior to return to service.
- Upon completion, check for the correct function of all valves which have been removed. Ensure that the valves turn on and off correctly. If it is found that any of the valves do not function correctly, the problem must be resolved prior to returning the burner to service

5.20 Main Valve Removal and Disassembly

To remove and disassemble the main valve, refer to Figure 10 and proceed as follows:

- Ensure that the burner is completely vented of fuel.
- Remove the bar handle as detailed in section 5.15.1.
- Remove the liquid valve handle as detailed in section 5.14.

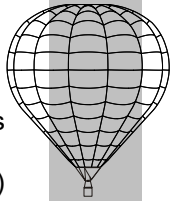

- Remove handle end cap as detailed in section 5.15.2
- Remove the double action mechanism as detailed in section 5.16.
- Remove the external valve body as detailed in section 5.17.
- Remove the antifriction washer (item 7).
- Access to the main valve may be improved by first removing the pilot valve. If it is considered necessary, remove the pilot valve as detailed in section 5.18.
- Using a 27 mm AF open-ended spanner, undo and remove the valve bonnet (item 10) from the main valve block.
- Extract the valve stem and shutter assembly (items 6 and 14) and the valve spring (item 13) from the bonnet (item 9).
- The valve stem is screwed in to the shutter and locked with a screw thread adhesive. It is recommended therefore that no attempt be made to separate the shutter from the stem, as it is likely that surfaces will be damaged in the process.
- The seal (item 16) is permanently fixed in to the shutter. Do not attempt to remove it.
- Remove the seal-retaining washer (item 13).
- Carefully remove the energised seal (item 12) from the bore inside the valve bonnet.
- Using a suitable soft-ended probe, carefully remove the "O" seals (item 27) from the valve stem (item 6).
- Remove the large "O" seal (item 28) from the underside of the valve bonnet collar where it mates with the valve block.
- Check the condition of all "O" seals. Damaged seals must be replaced.
- Check the condition of the shutter seal. The surface should be smooth and free from any damage. If the seal is considered to be defective, replace the complete shutter and stem assembly.
- Check the condition of the PTFE energised seal (item 12). If the seal is defective, it must be replaced.
- Check the condition of all the "O" seal grooves. If any significant damage such as scratching to the groove surfaces is detected, then the component must be replaced. As a guide, scratches detectable with a fingernail are considered significant.
- Check the condition of the bores inside the valve bonnet. If any significant scratches (particularly scratches running along the length of the bore) are detected, the bonnet must be replaced.
- Check the condition of the valve block lower surface where it mates with the large "O" seal on the underside of the bonnet collar. If any significant damage or deterioration is detected, contact Ultramagic for further advice.
- Re-assembly is generally the reverse procedure to disassembly. Prior to re-assembly, apply a thin smear of Krytox 125 grease to all the "O" seals and Molycote graphite grease to the antifriction washer (item 7).
- Prior to fitting the external valve body, connect the block to a compressed air supply not exceeding 6,8bar (100 psi). Apply leak detector fluid to all the joints of all valves removed. Check for any leaks. If any leaks are detected they must be corrected prior to return to service.
- Upon completion, check for the correct function of all valves which have been removed. Ensure that the valves turn on and off correctly. If it is found that any of the valves do not function correctly, the problem must be resolved prior to returning the burner to service.

5.21 Safety Button Removal and Disassembly

To remove the safety button, refer to Figure 13 and proceed as follows:

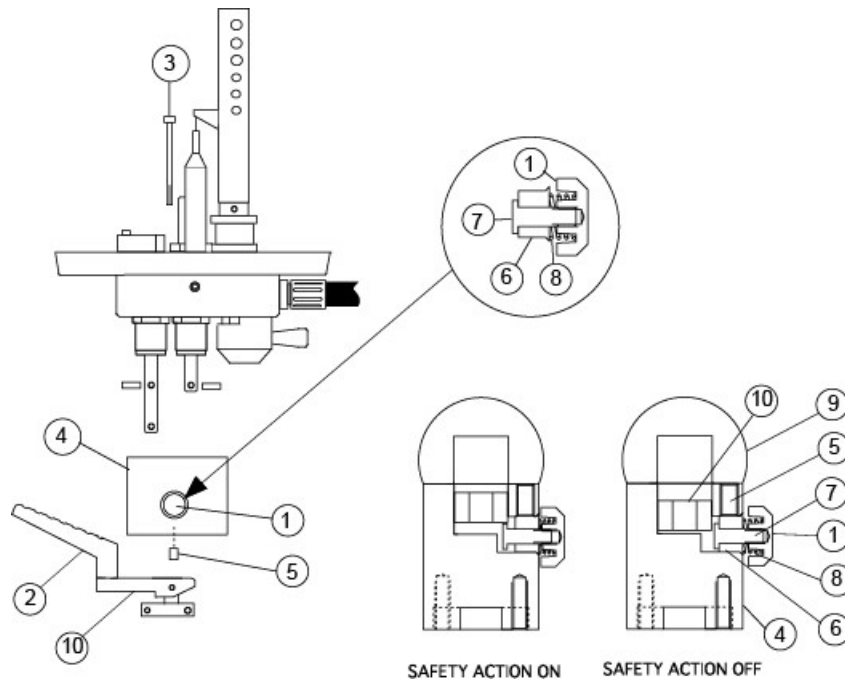
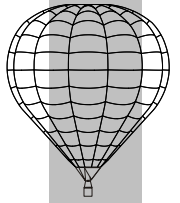

ITEM	DESCRIPTION	DWG / PART NUMBER
1	SAFETY BUTTON	CR-PPD-0066
2	BLAST VALVE HANDLE RH (ROUGH)	CR-PPD-D070
3	M5x50 ST STL HEX DRIVE DIN 912 SCREW	CR-PP-0017
4	VALVE EXTERNAL BODY RH	CR-PPD-D071
5	M6x6 ST STL HEX DRIVE DIN 914 GRUB SCREW	CR-N-0040
6	SAFETY BUTTON SUPPORT	CR-PPD-0068
7	SAFETY BUTTON STEM	CR-PPD-0067
8	SAFETY BUTTON SPRING	CR-PPD-0093
9	POWERPLUS DOUBLE BURNER BAR END CAP	CR-PPD-0072
10	DOUBLE ACTION VALVE CAM	CR-PPD-0076

Figure 13

- Ensure that the burner is completely vented of fuel.
- Remove the bar handle as detailed in section 5.15.1.
- Remove the liquid valve handle as detailed in section 5.14.
- Remove handle end cap as detailed in section 5.15.2
- Remove the double action mechanism as detailed in section 5.16.
- Remove the external valve body as detailed in section 5.17.
- Using a soft felt tip pen, put a small mark at the junction of the button assembly with the external valve body to keep the position of the plunger.
- Using a 3mm Allen key, loosen but do not remove the small grub screw (item 4).
- Withdraw the safety button assembly.
- Only if full disassembly is required, carefully unscrew the button (item 1). Remove the compression spring (item 7) located directly behind the button.
- Remove the plunger (item 6).
- Replacement is generally the reverse procedure to removal. Prior to assembly, apply a small quantity of Loctite 243 to the plunger thread. Note that the hole in the safety button support (item 5) is offset. When re-fitting the assembly back in to the external valve body, it will be necessary to set the position of the hole relative to the valve body. Set the position by rotating the assembly and aligning it with the marker. Having set the correct position, lock the assembly in position by tightening the grub screw (item 4).
- When the burner is fully assembled, check for correct function of the button by ensuring it locks out the main burner valve handle and releases when the handle is subsequently operated.

SECTION 6

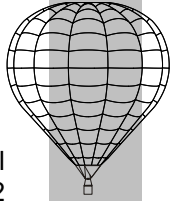

6.0 Annual / 100 Hour Inspection Requirements

6.1 General

The burner must be subjected to an inspection by an inspector approved by the national airworthiness authority in the state of registration. The inspection must be carried out every 12 months or 100 hours use, whichever is the sooner. The inspection requirements are detailed below.

6.2 Pre-functional Checks

Carry out all non-functional checks detailed in Section 4 (Preventative Maintenance).

6.3 Functional Test

6.3.1 Left and Right Main Burner Function (First Position)

Connect the burner to a suitable fuel supply. Operate the left and right main burner valves to the first (intermediate) position. Check for a good flame. Check that the ignition is immediate upon opening the valves. Check that the flame is quickly extinguished upon closing the valves.

6.3.2 Left and Right Double Action Function

Operate the left and right main valve handles to the fully open position. Check for a good main and liquid combination flame. Check that the ignition is immediate upon opening the valves. Check that the flame is quickly extinguished upon closing the valves.

6.3.3 Left and Right Liquid Valve Function

Connect the burner to a suitable fuel supply. Operate the left and right liquid burner valves. Check for a good flame. Check that flame ignition is immediate upon opening the valves. Check that the flame is quickly extinguished upon closing the valves.

6.3.4 Left and Right Pilot Regulator Valves

During operation it is possible that an oily residue progressively accumulates inside the bore of the pilot light regulator. This is quite normal depending on the fuel sourcing, and the design allows for certain amount of it. However, if the residue is allowed to build up and to stay for long periods, it may cause problems in time as residue changes consistency and begins to block the pilot light and pilot regulator jets and holes. This might lead to a pilot light flameout.

The regulator must therefore be checked to work properly and, in case of malfunction or if the presence of residues is suspected, regulator must be cleaned as follows:

- Remove and strip down the regulator as described in section 5.8.
- Using a soft cloth, wipe the inside of the regulator housing and the regulator piston and remove all traces of the residue.
- If the residue proves difficult to remove, a cloth soaked with a small amount of methanol solvent should be used.
- Check the condition of the fuel filter. Clean or replace if necessary.
- Check the inside of the jet and make sure it is clean. Remove any oil accumulation and any other dirt or contamination.
- Re-assemble the regulator as specified in section 5.8.

Having re-assembled the pilot regulator, its function must be tested as described below:

Connect the burner to a suitable fuel supply. Turn on the pilot regulator valve and ignite the pilot light. Check for a strong flame. Turn off the pilot regulator valve and check that the pilot light is quickly extinguished.

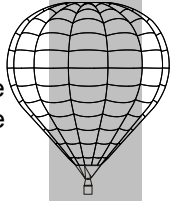

6.3.5 Fuel Filter

Remove the left and right fuel filter assemblies as detailed in Section 5.9. Check the condition of the filter. Replace the filter if necessary. Make sure that all holes in the filter body are clear.

6.3.6 Emergency Pilot Light Safety Button

Check for the correct function of the left and right emergency pilot light buttons. Ensure that the buttons maintain the main valve handles in the open position when operated.

6.3.7 Burner Rotation Stops

Check that the burner rotation stops are fully functional and that they prevent burner inversion in **both** axes.

6.4 Pressure Test

Connect the burner to a 7Bar (100 psi) air supply. Using soapy water, check the following areas for leaks:

- 6.4.1 All main valve-to-valve block joints
- 6.4.2 All main valve stems in open and closed position.
- 6.4.3 All liquid valve-to-valve block joints.
- 6.4.4 All liquid valve stems in open and closed position
- 6.4.5 All fuel hose joints.
- 6.4.6 All pressure Gauge to Valve block joints.
- 6.4.7 All pilot regulator valve to valve block joints.
- 6.4.8 All liquid fire jet assembly to valve block joints (liquid valve open).
- 6.4.9 All pilot light to valve block joints (pilot regulator valve open).
- 6.4.10 All coil post to valve block joints (main valve open).

SECTION 7

7.0 Troubleshooting

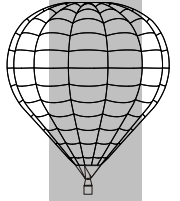

SYMPTOM	POSSIBLE CAUSE	CORRECTIVE ACTION
Main burner failure.	Fuel hose not connected to cylinder.	Connect hose to cylinder.
	Cylinder valve closed.	Open cylinder valve.
	Pilot light failure.	(See pilot light failure below)
Turbulent flame around the can	Jet ring bolts loose	Re-tighten bolts
Whistle while firing main flame	Bimetal strips inside jet ring loose	Re-tighten bolts securing the bimetal strips
	Dirt or distortion of the bimetal strips	Inspect/clean/replace the strips
Liquid burner failure.	Fuel hose not connected to cylinder.	Connect hose to cylinder.
	Cylinder valve closed.	Open cylinder valve.
	Pilot light failure.	(See pilot light failure below)
Persistent smell of fuel.	Fuel leak from burner or hose.	Air pressure test to determine location of leak. Repair as necessary.
Reduction in main burner power.	Jets in jet ring blocked.	Clean and unblock jets.
Main and / or liquid valves fail to close.	Contamination (dirt, swarf etc) between valve shutter and seat.	Remove contamination.
	Valve double-action mechanism frozen.	Grease mechanism (see section 5.19 and 5.20).
	Safety button activated.	Release button.
Pilot light fails to ignite.	Fuel cylinder valve off.	Turn valve on.
	Pilot valve off.	Turn valve on.
	Fuel Filter Assembly blocked.	Clean Fuel Filter Assembly
	Regulator filter blocked.	Clean filter.
	Regulator jet blocked.	Clean jet.
	Excessive oil deposits inside regulator.	Clean regulator.
	Failure of piezo igniter.	Repair igniter.
	Gap between igniter electrode and tag incorrect.	Re-set gap.
	Burner placed in excessive crosswind.	Move burner away from crosswind.
	Pilot valve knob incorrectly adjusted.	Re-set valve knob position.
Pilot light flame weak.	Fuel Filter Assembly blocked.	Clean Fuel Filter Assembly
	Regulator filter blocked.	Replace filter.
	Regulator jet blocked.	Clean jet.
	Excessive oil deposits inside regulator.	Clean regulator.
	Pilot valve knob incorrectly adjusted.	Re-set valve knob position.
	Piston lower seal detached from piston.	Replace piston assembly.
	Inlet and outlet hole in piston blocked.	Clean hole.
	Air inlet to pilot light blocked.	Clean mesh filter.
Pilot light flame very large.	Regulator jet not fitted or loose	Fit/secure jet.
	Piston seals not fitted or failed.	Repair seals.
Pilot light fails to extinguish.	Contamination (dirt, swarf etc) between valve shutter and seat.	Remove contamination.
	Pilot valve knob incorrectly adjusted.	Re-set valve knob position.
Burner gimbal action too tight or too loose.	Friction setting on gimbal mechanism incorrectly set.	Adjust friction setting.
Burner excessively hot.	Fuel pressure too low.	Run burner within recommended fuel pressure range.
	Fuel cylinder empty, burner running on vapour only.	Connect burner to a full cylinder.
Safety button fails to operate correctly.	Offset hole in button assembly incorrectly set.	Adjust assembly position in external valve body.

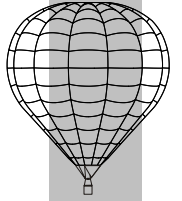

APPENDIX I

Annual / 100 Hours Burner Inspection Checklist

REQUIREMENT	REFERENCE	OKAY	COMMENTS
Burner Can Fixings	4.2		
General Cleaning	4.3		
Main jets	4.4.1		
Coil Fixings	4.4.2		
Coil Tubing	4.4.3		
Coil Support Rivets	4.4.4		
Pilot Light Strength	4.5		
Igniter Spark	4.6		
Fuel Hoses	4.7		
Pressure Gauge	4.8		
Burner Mounting	4.9		
Main Burner Function	6.3.1		
Double Action Function	6.3.2		
Liquid Valve Function	6.3.3		
Pilot Light	6.3.4		
Fuel Filter	6.3.5		
Emergency Pilot Light Button	6.3.6		
Burner Rotation Stops	6.3.7		
Main Valve Pressure Test	6.4.1 6.4.2		
Liquid Valve Pressure Test	6.4.3 6.4.4		
Fuel Hose Pressure Test	6.4.5		
Pressure Gauge Pressure Test	6.4.6		
Pilot Regulator Valve Pressure Test	6.4.7		
Liquid Fire Jet Pressure Test	6.4.8		
Pilot Light Pressure Test	6.4.9		
Coil Post Pressure Test	6.4.10		

**S
1
2
-
P
O
W
E
R
P
L
U
S

D
O
U
B
L
E**