



FLIGHT MANUAL

for

ULTRAMAGIC HOT AIR BALLOONS

H 31 42 56 65 77

V 56 65 77 90 105

S 50 70 90 105 130 160

T 150 180 210

F Special Shapes

**M 42 56 56C 56Z 60Z 65 65C 65Z
70Z 74Z 77 77C 90 105 120 130
145 160**

N 180 210 250 300 355 425 500

Z 90

B 26 40 50 55 60 70

Serial number

Approval

Date

Rev. 17

ULTRAMAGIC,S.A.
Aerodrom Igualada-Odena s/n
08700 IGUALADA (SPAIN)
tel +34 93 8042202
e-mail admin@ultramagic.com

Document name : FM04US
Initial Issue date 08 July 2008

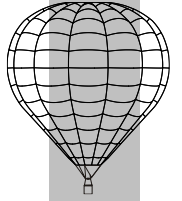

ULTRAMAGIC S.A

This Flight Manual has been prepared for the following balloon

Registration:

Type:

Serial Number:

Volume:

Build Standard

I hereby certify that this Flight manual, as prepared for the above balloon and incorporating the amendments listed, conforms to the build standard of the above balloon at the time of the issue of the Certificate of Airworthiness.

Signed: Date:

Applicability

This Flight Manual applies to all Ultramagic S.A. balloons listed in section 6.3. For non-standard shaped balloons or balloons not listed in 6.3 see relevant Flight Manual Supplement in section 9.

FAA approved or pendent of approval for U.S. registered aircraft in accordance with FAR 21.29.

Build Standard

See page 0.2 for build standard.

**O
R
E
V
I
S
I
O
N
S
/
C
O
N
T
E
N
T
S**

BUILD STANDARD

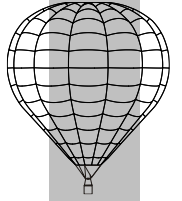

Registration

Envelope Type

Envelope Serial No.

Envelope Volume**Envelope weight**.....

Basket Type

Basket Serial No.**Basket weight**.....

Burner Type**Burner weight**.....

Burner Serial No.

I hereby certify that the above build standard meets the requirements stated in this Flight Manual at the time of issue of the Certificate of Airworthiness.

Signed: Date

WARNING

- Any changes to the equipment listed on this Build Standard sheet without meeting the above requirements, will invalidate the Certificate of Airworthiness.
- Latest editions and revisions of the Flight Manual are published in the web www.ultramagic.com
- To subscribe/unsubscribe to receive automatically information on the approved updates of the Flight Manual, contact support@ultramagic.com

**O
R
E
V
I
S
I
O
N
S
/
C
O
N
T
E
N
T
S**

LIST OF APPROVED REVISIONS

Revision N°	Modifications (Brief description)	Approval N° Approval Date
1	Corrections of MTOM according to B02CE	EASA.CSV.BA.01002 29/July/2008
2	Limitation section amended Loading section amended Other Manufacturer's Equipment section amended Documentary changes Supplements 4, 13, 29, 30, 31, 33 added	EASA.CSV.BA.01020 (FAA Project-Nr TD0333CE-B) 11/Mar/2010
3	Supplements 38, 39 and 43 added	EASA.CSV.001000 8071 (FAA Project AT00395CE-B) 21/Sep/2012
4	Section 1, 2, 3, 4, 5, 6, 7 and 9 amended (documentary changes) Supplements 38 and 39 amended	EASA.CSV.001002 2798 (FAA Project AT00660CE-B) 23/Jul/2015
5	Section 9 amended Supplements 50 and 51 added	EASA 0060046591 (FAA Project AT00767CE-B) 27/May/2016
6	Section 9 amended Supplement 4 amended	Approved under the authority of DOA ref. EASA.21J.351 09/May/2017
7	Section 9 amended Supplement 4 amended	Approved under the authority of DOA ref. EASA.21J.351 11/May/2017
8	Section 9 amended Supplement 39 amended	Approved under the authority of DOA ref. EASA.21J.351 15/Sep/2017
9	Section 8 & 9 amended Supplement 4 amended Supplement 31 amended Supplement 34 added Supplement 48 added	Approved under the authority of DOA ref. EASA.21J.351 EASA 0060063166 EASA 0060052432 (FAA Project AT00816CE-B) 21/Aug/2018
10	Addition of the N-500 model to the first page	Approved under the authority of DOA ref. EASA.21J.351 18/03/2019
11	Supplement 13 amended	Approved under the authority of DOA ref. EASA.21J.351
12	Addition of the B Series to the first page	EASA 0060083204 (FAA Project AT11501IB-B) 07/11/2023

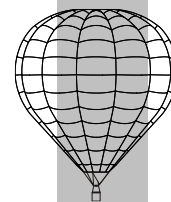

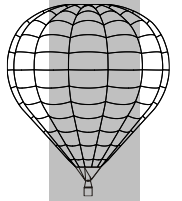

REVISIONS / CONTENTS

Revision N°	Modifications (Brief description)	Approval N° Approval Date
13	Supplement 4 amended	Approved under the authority of DOA ref. EASA.21J.351 15/12/2022
14	Addition of the M-56z, M-60z, M-65z, M-70z and M-74z models.	EASA 0060088143 (FAA Project AT11821IB-B) 06/12/2023
15	Supplement 39 and 48 amended.	EASA 0060090150
16	Supplement 4, 13, 29, 30 and 31 amended.	Approved under the authority of DOA ref. EASA.21J.351 25/07/2024
17	Supplement 4, 30, 31, 33 and 50 amended.	Approved under the authority of DOA ref. EASA.21J.351 08/10/2024

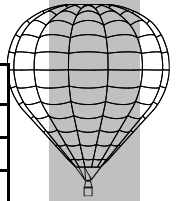

LIST OF EFFECTIVE PAGES

Page	Nº	Date	Page	Nº	Date	Page	Nº	Date
0.0	17	08-Oct-24	6.7	4	23-July-15			
0.1	0	08-July-08	6.8	4	23-July-15			
0.2	15	09-Feb-24	6.9	4	23-July-15			
0.3	12	07-Nov-23	6.10	4	23-July-15			
0.4	17	08-Oct-24	6.11	4	23-July-15			
0.5	17	08-Oct-24	6.12	4	23-July-15			
0.6	4	23-July-15	6.13	4	23-July-15			
0.7	4	23-July-15	6.14	4	23-July-15			
0.8	14	06-Dec-23	6.15	4	23-July-15			
1.1	0	08-July-08	6.16	14	06-Dec-23			
1.2	0	08-July-08	6.17	4	23-July-15			
1.3	4	08-July-08	6.18	4	23-July-15			
2.1	4	23-July-15	6.19	4	23-July-15			
2.2	4	23-July-15	6.20	4	23-July-15			
2.3	14	06-Dec-23	6.21	15	09-Feb-24			
2.4	4	23-July-15	6.22	4	23-July-15			
3.1	4	23-July-15	6.23	4	23-July-15			
3.2	4	23-July-15	6.24	0	08-July-08			
3.3	4	23-July-15	6.25	4	23-July-15			
3.4	4	23-July-15	6.26	0	08-July-08			
4.1	4	23-July-15	7.1	0	08-July-08			
4.2	4	23-July-15	7.2	4	23-July-15			
4.3	12	07-Nov-23	7.3	0	08-July-08			
4.4	4	23-July-15	8.1	17	08-Oct-24			
4.5	4	23-July-15	9.1	17	08-Oct-24			
4.6	4	23-July-15	A.1	14	06-Dec-23			
4.7	0	08-July-08	A.2	14	06-Dec-23			
4.8	0	08-July-08	A.3	14	06-Dec-23			
4.9	4	23-July-15	A.4	14	06-Dec-23			
4.10	4	23-July-15	A.5	14	06-Dec-23			
4.11	4	23-July-15	A.6	14	06-Dec-23			
4.12	4	23-July-15	A.7	14	06-Dec-23			
4.13	4	23-July-15	A.8	14	06-Dec-23			
4.14	4	23-July-15	A.9	14	06-Dec-23			
4.15	4	23-July-15	A.10	14	06-Dec-23			
5.1	4	23-July-15	A.11	14	06-Dec-23			
5.2	15	09-Feb-24	A.12	14	06-Dec-23			
5.3	15	09-Feb-24	B.1	4	23-July-15			
5.4	4	23-July-15	C.1	0	08-July-08			
5.5	4	23-July-15	C.2	4	23-July-15			
5.6	4	23-July-15	D.1	4	23-July-15			
5.7	15	09-Feb-24	D.2	4	23-July-15			
5.8	15	09-Feb-24						
5.9	14	06-Dec-23						
5.10	14	06-Dec-23						
6.1	4	23-July-15						
6.2	4	23-July-15						
6.3	14	06-Dec-23						
6.4	14	06-Dec-23						
6.5	4	23-July-15						
6.6	0	08-July-08						

O
R
E
V
I
S
I
O
N
S
/
C
O
N
T
E
N
T
S

CONTENTS

Section 1 – General Information	<ul style="list-style-type: none"> 1.1 Introduction 1.2 Certification Basis 1.3 Warnings, Cautions and Notes 1.4 General Description
Section 2 – Limitations	<ul style="list-style-type: none"> 2.1 Introduction 2.2 Meteorological Limitations 2.3 Condition of the balloon <ul style="list-style-type: none"> 2.3.1 Acceptable damage 2.4 Safety equipment (Minimum Equipment) 2.5 Fuel 2.6 Loading 2.7 Crew 2.8 Vertical velocities 2.9 Internal temperature 2.10 Deflation systems 2.11 Baskets 2.12 Min. Burner requirements 2.13 Fuel Cylinders 2.14 Tethered Flight 2.15 Other Manufacturers Equipment 2.16 Night Flying
Section 3 – Emergency procedures	<ul style="list-style-type: none"> 3.1 Introduction 3.2 Pilot light failure 3.3 Icing of regulator on systems with vapor pilot light 3.4 Failure of burner valve 3.5 Dropping of temp. flag 3.6 Envelope damage 3.7 Emergency landing 3.8 Fire in the air 3.9 Fire on the ground 3.10 Contact with power lines 3.11 Accidental operation of FDS in flight

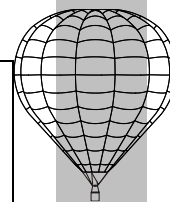

**O
R
E
V
I
S
I
O
N
S
/
C
O
N
T
E
N
T
S**

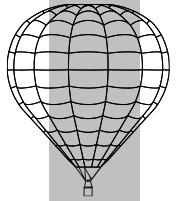

CONTENTS

Section 4 – Standard Procedures	<ul style="list-style-type: none"> 4.1 Introduction 4.2 Choosing an inflation site 4.3 Meteorological conditions 4.4 Load chart 4.5 Preparation for flight <ul style="list-style-type: none"> 4.5.1 Initial pre-flight checks 4.5.2 Rigging the basket/burner 4.5.3 Testing the burner 4.5.4 Envelope 4.6 Deflation systems <ul style="list-style-type: none"> 4.6.1 Parachute 4.6.2 Fast deflation system 4.7 Inflation 4.8 Preparation for take off <ul style="list-style-type: none"> 4.8.1 Checks 4.8.2 Passenger briefings 4.9 Take off 4.10 Control during flight <ul style="list-style-type: none"> 4.10.1 Maneuvering in flight 4.10.2 Fuel management 4.10.3 Gusting 4.10.4 Thermals 4.11 Landing <ul style="list-style-type: none"> 4.11.1 Landing without wind (parachute) 4.11.2 Landing with wind (parachute) 4.11.3 Landing with wind (FDS) 4.11.4 Landing large balloons
Section 5 - Loading	<ul style="list-style-type: none"> 5.1 Introduction 5.2 Table of empty weights 5.3 Load chart <ul style="list-style-type: none"> 5.3.1 Calculation example 5.4 Table of compatibility 5.5 Minimum Take off weights 5.6 Reduced Maximum TO Mass Operations

CONTENTS

Section 6 – Balloon and Systems Description	6.1 Introduction 6.2 Description 6.2.1 Envelope 6.2.2 Burner and Burner frame 6.2.3 Basket 6.2.4 Fuel Cylinders 6.2.5 Flight controls 6.3 Dimensions and weights 6.4 Monitoring instruments 6.5 Bonnano quick release 6.6 Pilot restraint harness 6.7 General illustration
Section 7 - Balloon Handling Maintenance and Care	7.1 Introduction 7.2 Inspection periods 7.3 Alterations or repairs 7.4 Ground handling and transportation. 7.5 Storage 7.5.1 Envelope 7.5.2 Basket 7.5.3 Burner 7.5.4 Cylinders 7.6 Cleaning and Care
Section 8 – Other Manufacturers Equipment	8.1 Requirements 8.2 Supplements
Section 9 – Supplements	9.1 Introduction 9.2 Supplement list
Appendix A	Descent rates and altitude recovery
Appendix B	Flight Instruments list
Appendix C	Quick reference Pre-flight check list
Appendix D	Minimum Basket Space requirements.

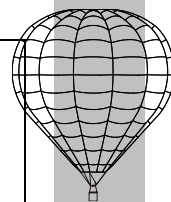

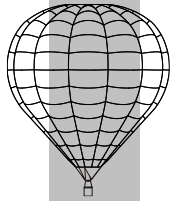

SECTION 1

GENERAL INFORMATION

1.1 Introduction

This balloon flight manual has been prepared to provide pilots and instructors with information for the safe operation of all Ultramagic free hot air balloons.

Whenever necessary, for US operations please refer to Unit Conversion Table (Supplement 20).

1.2 Certification Basis

All types of balloons for which this manual is applicable have been certified and approved by E.A.S.A.

1.3 Warnings, cautions and notes

The following definitions apply to warnings, cautions and notes used in this flight manual.

WARNING – means that the non-observation of the corresponding procedures leads to an immediate or important degradation of flight safety.

CAUTION – means that the non-observation of the corresponding procedure leads to a minor degradation to flight safety or to a long term degradation of flight safety.

NOTE – draws the attention on any special item not directly related to safety but which is important or unusual.

1.4 General Description

A hot air balloon is a free balloon in which the lifting force consists of hot air produced by means of a propane burner, using this gas in its liquid form. All balloons belong to one of the FAI categories indicated in the tables of Section 6.3.

The aerostat is remarkably simple in its conception and handling. It consists of three main parts: Envelope, fuel system (burner with load frame and fuel cylinders) and finally a basket of woven construction or seat to carry the pilot and passengers.

Envelopes are made of high resistance polyamide fabric reinforced by polyester load tapes. These tapes carry the forces due to loading and transmit the forces to the load frame.

The burner is a high output device for converting the fuel (liquid propane) stored in the fuel cylinders into heat energy.

See section 6 for a detailed description of the balloons and their systems.

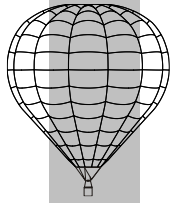

**1
G
E
N
E
R
A
L
I
N
F
O
R
M
A
T
I
O
N**

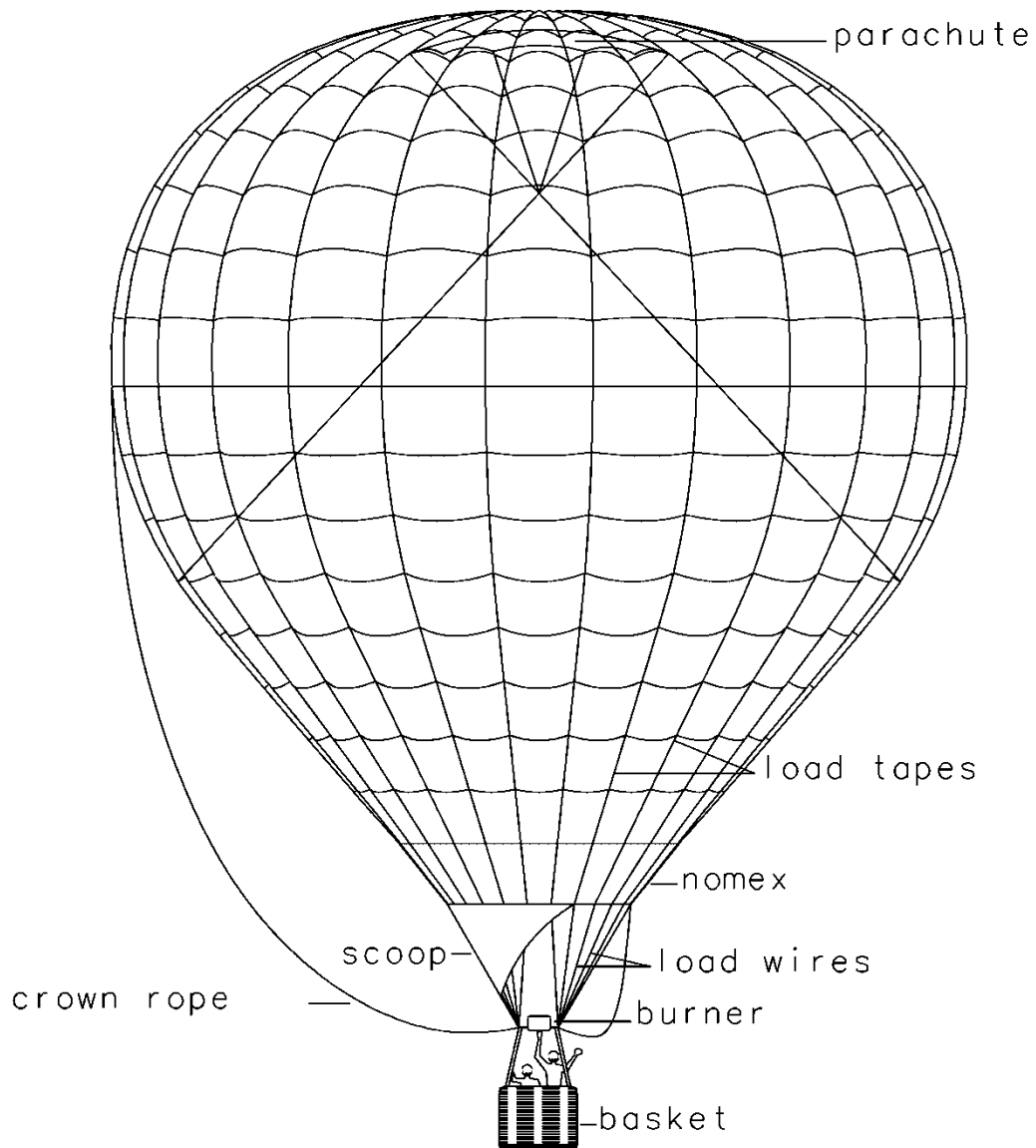

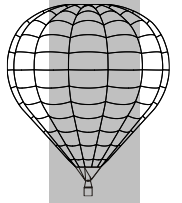

**1
G
E
N
E
R
A
L
I
N
F
O
R
M
A
T
I
O
N**

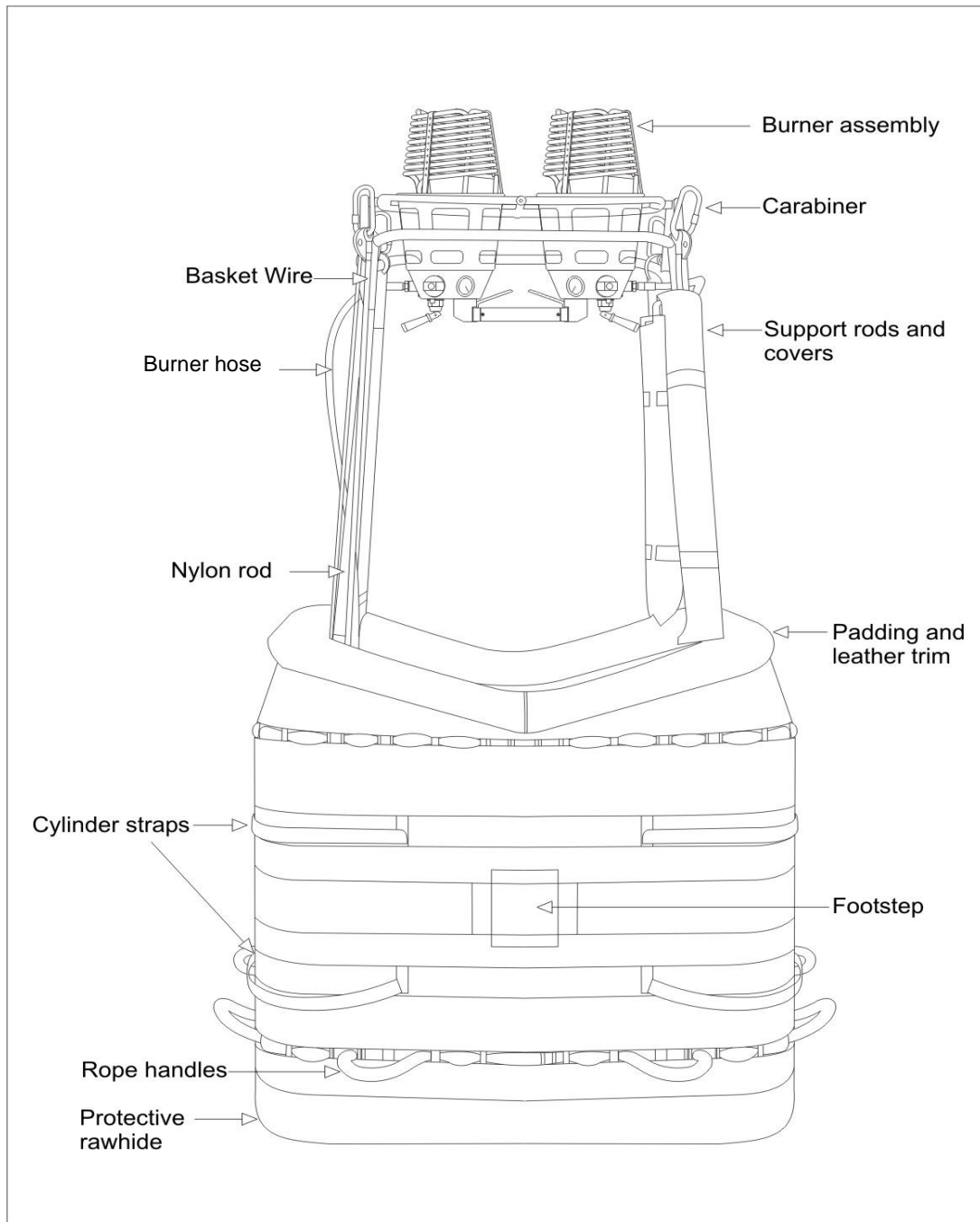

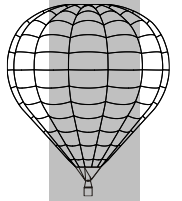

SECTION 2

LIMITATIONS

2.1 Introduction

Section 2 details the operating limitations for the balloon, standard systems and standard equipment.

The limitations included in this section and in Section 9 have been approved by EASA.

WARNING: Compliance with the approved limitations is mandatory.

2.2 Meteorological Limitations

The surface wind speed at take-off must not exceed 15 kt (27 km/h or 7.5 m/s).

There should be no, or only very weak thermal activity.

There should be no sign of storms, either active or building.

2.3 Condition of balloon

WARNING:

The balloon must not take off if it fails any of the pre-flight checks.

The balloon must not take off with any major damage above the lower third of the envelope, or if there is any damage to wires, cables, tapes, load carrying parts below this level, the fuel system, or the burner.

The balloon must not take off if it has not been maintained and inspected in accordance with the manufacturer's maintenance manual.

2.3.1 Acceptable Damage:

Damage to the fabric in the lower third of the envelope must be limited to an area affecting no more than 3 panels, being accepted even without fabric, but not with any tape, vertical or horizontal, damaged. These panels may be adjacent.

Holes no greater than 10mm (1/4 in) in diameter (e.g. cigarette burn) are permitted elsewhere on the envelope.

These holes must not be within 25mm (1 in) of a load tape, with no more than 5 in any one panel and be no closer than 50 mm (2 in) to each other. No more than 3 panels in the upper two thirds of the envelope may have these small holes.

No damage is permitted to any part of the burner, fuel or load suspension system.

2.4 Safety Equipment (Minimum equipment)

All of the following equipment must be in working order and must be carried in the balloon basket.

- 1 One fire extinguisher of at least 2 kg (4.4 lb), or two of 1 kg (2.2 lb) conform to EN3 which use dry powder or with an approved equivalent level of safety (e.g. ANSI/UL711).

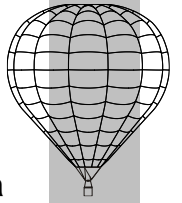

- 2 Sufficient auxiliary means of ignition (matches, lighter or similar).
- 3 Protective gloves for the pilot.
- 4 An envelope temperature indicator, which either gives a warning signal or a continuous reading type instrument.
- 5 Fuel gauges on each cylinder.
- 6 A means of measuring fuel consumption (e.g. watch or stop watch) must be carried.
- 7 Altimeter.
- 8 Variometer to measure rate of climb and descent.
- 9 On flights when it is intended to climb higher than 300 m (1,000 ft), an ambient temperature thermometer and a load chart provided by the manufacturer must be carried.

2.5 Fuel

A minimum of one cylinder per burner is to be carried for flight except in the case of a single burner where two cylinders must be used. These cylinders must be full at take-off. Where vapor pilot lights are fitted to the burner then a vapor supply must be provided for each pilot light.

Aluminum "Worthington" cylinders may be used as long as the propane fuel is free of caustic soda. In all other cases, stainless steel cylinders must be used.

The approved fuel is commercial propane, which can contain some butane.

Butane may also be used as long as the pressure is greater than 3 bar (43.5 psi). This pressure can be achieved by pressurizing the cylinders with nitrogen.

Fuel tanks pre-pressurized with nitrogen or other inert gas must not be used to provide fuel to "vapor" pilot light.

Gas for refueling must be completely clean and the use of a fuel filter is strongly recommended.

WARNING:

Minimum dynamic pressure accepted for use with the burner is 3 bar (43.5 psi). Maximum authorized dynamic pressure allowed for use of the burner is 10 bar (145 psi) and the maximum cylinder pressure allowed for use of the burner is 12 bar (174 psi).

CAUTION: extra care should be taken when operating at low burner pressures.

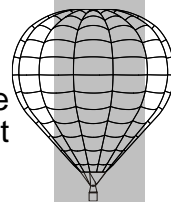

2.6 Loading

The total take-off weight must never exceed the upper limit determined with the use of the load chart supplied by the manufacturer in Section 5.2. At no time must the maximum lift (Lmax) listed in Section 5.2 be exceeded.

At the time of landing the actual weight must never be less than that specified in the table supplied by the manufacturer in section 5.5. This applies to all balloons of Volume greater than 90,000 ft³.

Enough room must always remain in the basket for the pilot to readily access all flight and fuel system controls and for all occupants to prepare for a hard landing. The minimum space requirements for passengers must be maintained in accordance with appendix D.

2.7 Crew

Minimum: 1 pilot

2.8 Vertical velocities

Maximum rate of climb 3 m/s (600 ft/min), or 5 m/s (1,000 ft/min), if an internal envelope temperature indicator is carried and the maximum permitted temperature is not exceeded.

Maximum rate of descent is 5 m/s (1,000 ft/min).

For MV series (M56c, M65c, M77c) the Maximum rate of climb and descent is 7 m/s (1,400 ft/min) if an internal envelope temperature indicator is carried and the maximum permitted temperature is not exceeded.

For MZ series (M-56z, M-60z, M-65z, M-70z, M-74z) the Maximum rate of climb is 3m/s (600 ft/min), or 9 m/s if an internal envelope temperature indicator is carried and the maximum temperature is not exceeded. Maximum rate of descent is 8 m/s.

2.9 Internal temperature

In normal use, the maximum continuous internal temperature adjacent to the fabric is 120 °C (250 °F).

The internal temperature adjacent to the fabric must never exceed 130 °C (266 °F).

2.10 Deflation systems

WARNING: It is prohibited to use the red rope of the FDS rapid deflation system (see section 6.2.5.3) at an altitude higher than 10 m (30 ft) above the ground.

CAUTION: In flight use of the parachute vent system should be no longer than 3 seconds at any one time. Reuse must not be attempted until the envelope has re-inflated.

CAUTION: For MZ series, at high descend rates the envelope profile may suffer perceptible deformations, especially below the equator, adopting a characteristic funnel shape. During such manoeuvres, it is forbidden to use the parachute until the balloon has been re-inflated and has returned to its normal shape.

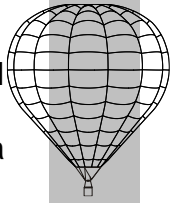

2.11 Baskets

2.11.1 Rotation vents must be fitted to envelopes when used with partitioned baskets.

2.11.2 The maximum number of passengers in any one compartment of a basket is 6.

2.12 Minimum Burner requirements.

· The Powerplus BMK-008 Single burner may only be used in balloons up to 120,000 ft³ (3,400 m³). Other single burners may only be used in envelopes up to 105,000 ft³ (3,000 m³).

· The Powerplus Maxi BMK-050 Double burner may only be used in balloons up to 300,000 ft³ (8,500 m³). Other double burners may only be used in envelopes up to 210,000 ft³ (6,000 m³).

· The Powerplus Maxi BMK-050 Triple burner may only be used in balloons up to 425,000 ft³ (12,040 m³). Other triple burners may only be used in envelopes up to 300,000 ft³ (8,500 m³).

The quad burner may only be used in balloons greater than 300,000 ft³ (8,500 m³).

2.13 Fuel Cylinders

1. All cylinders must be fitted with a padded jacket.
2. A minimum of 2 cylinder straps of an approved design must be fitted to each cylinder. These should be fitted so as not to allow any up and down as well as lateral movement.
3. No part of any cylinder must protrude above the top of the basket.

2.14 Tethered Flight

Tethered flight is allowed where the local authorities permit this. Refer to Ultramagic flight manual supplement 1 in section 9 where applicable.

2.15 Other Manufacturers equipment

Equipment produced by certain other manufacturers may be used with Ultramagic envelopes. Refer to Section 8 of this Flight Manual for limitations.

2.16 Night Flying

Night flying is permitted when all applicable regulations, laws and requirements on equipment and licensing are met.

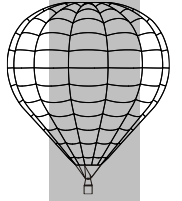

SECTION 3

EMERGENCY PROCEDURES

3.1 Introduction

Section 3 provides checklists and amplified procedures for coping with emergencies that may occur.

3.2 Pilot light failure

3.2.1 Single burner unit

If for any reason the pilot light should go out, try to relight it immediately with the piezoelectric ignition system, matches or other igniters.

In case of failure to re-ignite proceed as follows

1. Close the vapor and liquid take-off valve(s) on the corresponding cylinder.
2. Open completely the blast valve on the burner.
3. Open slightly the liquid take-off valve on the cylinder on the same side to allow a small flow of propane.
4. Ignite the main burner, and regulate the flame using the liquid valve on the cylinder, taking care not to allow it to extinguish.
5. Land as soon as possible

3.2.2 Burner with additional "quiet" burner

1. Open the valve on the "quiet" burner very slightly and ignite it.
2. Adjust the level of the "quiet" burner to act as an adequate pilot light.
3. Continue to use the main burner as usual, carefully monitoring the "quiet" burner valve for freezing. If freezing occurs, follow 3.2.1.
4. Land as soon as possible.

3.2.3 Double, triple or quadruple burner unit

1. Continue the flight with another burner while trying to re-ignite. If pilot lights fail, proceed as described in 3.2.1 or 3.2.2, whichever is appropriate.
2. Land as soon as possible.

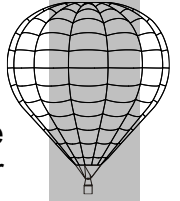

3.3 Icing of the regulator on systems using a vapor pilot light.

When the fuel cylinders are horizontal during inflation, the regulator on the vapor take off is not fed with gas, but with liquid propane. If the time taken for inflation is too long, ice may form, which could extinguish the pilot light. If this happens, shut down the vapor take-off valve at the cylinder. Wait until all the liquid in the regulator and connections has burned off, and the ice melts, then reopen the valve and re-ignite the pilot light.

3.4 Failure of a burner valve

In case of malfunction of one main valve, transfer control immediately to another burner or with a single burner to the other fuel supply.

- If the blast valve is stuck in the open position or it is leaking, close down the corresponding valve on the cylinder, and burn out the line if necessary, and use the other valve.
- If the blast valve is stuck in the closed position, use the other valve.
- Land as soon as possible.

3.5 Dropping of the temperature flag

If the envelope temperature flag drops during flight then proceed as follows:

1. Take all precautions to reduce envelope temperature.
2. Descend immediately and land as soon as possible.
3. Inspect the temperature tags to determine if the envelope has been overheated.
4. Carry out a fabric test if the fabric shows signs of overheating.
5. Repair or replace fabric as required in accordance with the maintenance manual.
6. Replace the temperature flag.

NOTE: The dropping of the flag does not automatically mean that the envelope has been overheated. In many cases this is just a warning of a potential overheat.

3.6 Envelope damage

Should the envelope be damaged in flight proceed as follows:

1. Increase the rate of burning to compensate for the loss of heat depending on the size of the hole.
2. Land as soon as possible.

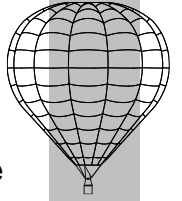

3.7 Emergency landing

If a hard landing or a high wind landing is anticipated, proceed as follows:

1. Brief everyone to brace with knees slightly bent, to hold on firmly to the handles inside the basket, and to watch the progress of the landing.
2. Warn the passengers not to leave the basket until instructed.
3. Take off all glasses and instruct passengers to remove glasses.
4. Warn everybody of a possible second impact.
5. Throw overboard any unnecessary ballast, taking all possible care not to cause any damage below when doing so.
6. Extinguish the pilot lights.
7. Shut off all cylinder valves and vent the fuel lines before impact.

3.8 Fire in the air

Should a fire occur during flight then follow the instructions below in the order shown:

1. Turn off the propane valve at the cylinder.
2. Use the fire extinguisher on the source of the flame.
3. Determine the location of the fire and extinguish it.
4. Use another burner/valve unit if necessary.
5. Maintain control of the height of the balloon all times.
6. Land as soon as possible.

3.9 Fire on the ground

Should a fire occur on the ground, follow the instructions below in the order shown:

1. Turn off the propane valve at the cylinder.
2. Use the fire extinguisher on the source of the flame.
3. Once the fire is extinguished determine the reason and correct it completely, otherwise abort the flight.

WARNING:

If fire burns more than 20 seconds around a cylinder, abandon the basket making sure not to allow the balloon to lift off when the weight is reduced. The pilot must be the last to exit the basket with the rip line in his hand.

3.10 Contact with power lines

Any contact with electric power lines is extremely dangerous and should be avoided at all costs. If contact cannot be avoided then steps should be taken to ensure that contact is made only with the envelope above the flying wire level. This may best be achieved by descending which will also mean the basket is closer to the ground to allow escape.

If time permits close all fuel lines and vent off fuel before contact. If safety conditions permit, avoid touching the ground at all costs until you have been informed that the power line has been switched off.

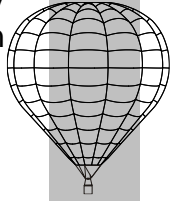

3.11 Accidental operation of FDS in flight.

Immediately release the vent line and re-close the parachute by pulling on the parachute line and turn on the burner to replace as much heat as possible.

WARNING-

The FDS line will not automatically retract when released. It must be closed by using the parachute line.

SECTION 4

STANDARD PROCEDURES

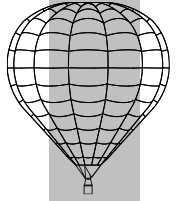

4.1 Introduction

Section 4 provides checklists and amplified procedures for the conduct of normal operation. Normal procedures associated with optional systems and operations can be found in Section 9

4.2 Choosing an inflation site

The selected location must have the following conditions:

- A flat even surface of sufficient size for safe inflation free of vertical obstructions, sharp stones, thorny bushes or anything else that might cause damage to the envelope, and if possible sheltered from the prevailing wind. There should be sufficient space for positioning of vehicle(s) for tethering to.
- The surface should preferably be grass, but without any risk of fire. If there is any risk of setting fire to vegetation, place a Nomex blanket between the burner and the base of the envelope.

4.3 Meteorological Conditions

When planning a flight the limitations set in section 2.2 must be adhered to. In addition one should consider the possibility of severe weather approaching, the possible effect of sea breezes and also wind direction. Care should be taken to ensure that the wind direction would not take you into a prohibited area or other controlled areas. The actual weather conditions should be continually monitored during preparation and modified or cancelled if required. The effect of ambient temperature on fuel pressure must also be considered.

4.4 Load chart

Before each flight it is necessary to calculate the total all up weight and check that it is below the maximum permitted payload. The maximum payload varies with ambient air temperature and altitude, and is found by consulting the load chart supplied by the manufacturer.

Excess weight will result in a high internal temperature, which can damage the envelope fabric. If an ascent to over 300 m (1,000 ft) is to be made, it may be necessary to consult the load chart during the flight. The change in temperature and altitude, together with the weight loss due to fuel consumption, may make the pilot change the flight parameters, particularly as far as altitude is concerned. Use of the load chart is explained in Section 5.3.

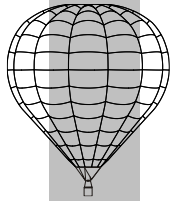

4.5 Preparing the aerostat for flight

Brief crew as to the roles they are to perform.

4.5.1 Initial Pre-flight checks

Before preparing for every flight, the balloon should be inspected to comply with the following requirements:

4.5.1.1 – Documents

Balloon Flight Manual including AD's and SB's, an airworthiness certificate, a certificate of registration, a certificate of the fuel cylinders and a certificate of burner, basket and/or fuel cylinders from another manufacturer.

4.5.1.2 - Envelope and deflation system:

No holes or tears in the fabric above the lower third of the envelope.
All horizontal and vertical load tapes in good condition.
All cords and pulleys are attached and working correctly.
The parachute or FDS lines are free of tangles and operating correctly.
Flying wires are free of kinks or damage

4.5.1.3 - Burner and fuel system:

Check the burner and blast valves, the condition of the hoses, and their connections to the fuel tanks, making sure that there are no leaks. Perform a burner test and also check the pilot lights.

4.5.1.4 - Basket:

General condition, tanks secured, correct attachment of burner frame and wires.

4.5.1.5 – Other Equipment:

Check Altimeter, variometer and thermometer. Also matches, gloves, First Aid kit and Fire Extinguisher, all in working order.

4.5.2 Rigging the basket and burner

Place the basket upright where the inflation is to take place.
Check the wires of the basket for damage.

- Ensure that the fuel cylinders are firmly strapped into the basket, and that their contents are sufficient for the flight. Check also that the cylinders to be used for

inflation are full and correctly orientated. Cylinders used for liquid supply during inflation must be positioned so that the liquid valve is in the lower position when the basket is laid on its side. Where a vapor supply is also required the cylinder should be positioned so that the vapor valve is on top when the basket is laid on its side

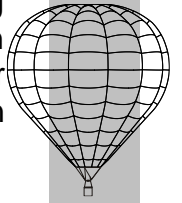

- Place the support rods to support the burner in their sockets in the basket, then position the upper end of the rods in the sockets on the burner frame. Connect the basket cables to the burner frame using carabiners. On baskets with double corner lugs each cable attaches to its own lug. See following drawings.

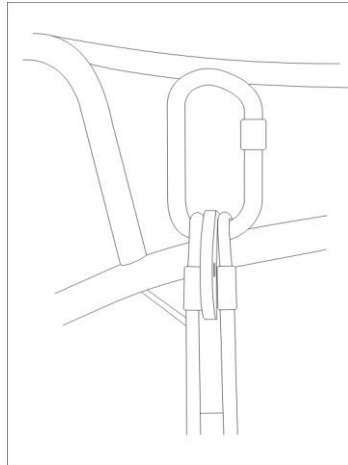

Ultramagic single corner lug attachment (1 carabiner)

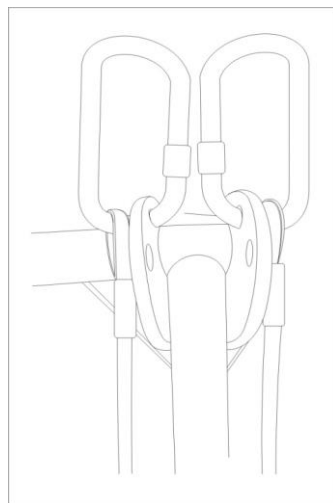

Ultramagic double corner lug attachment (2 carabiners)

For B Series a single carabiner with a minimum working load of 900kg (or 450kg for B-26, B-40, B-50 and B-55) may be used on each corner of the burner frame to attach the flying wires from the envelope. Those carabiners shall be engraved with limit load and must be supplied or approved by Ultramagic.

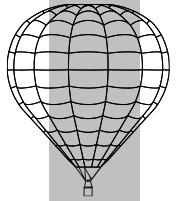

4 S T A N D A R D P R O C E D U R E S

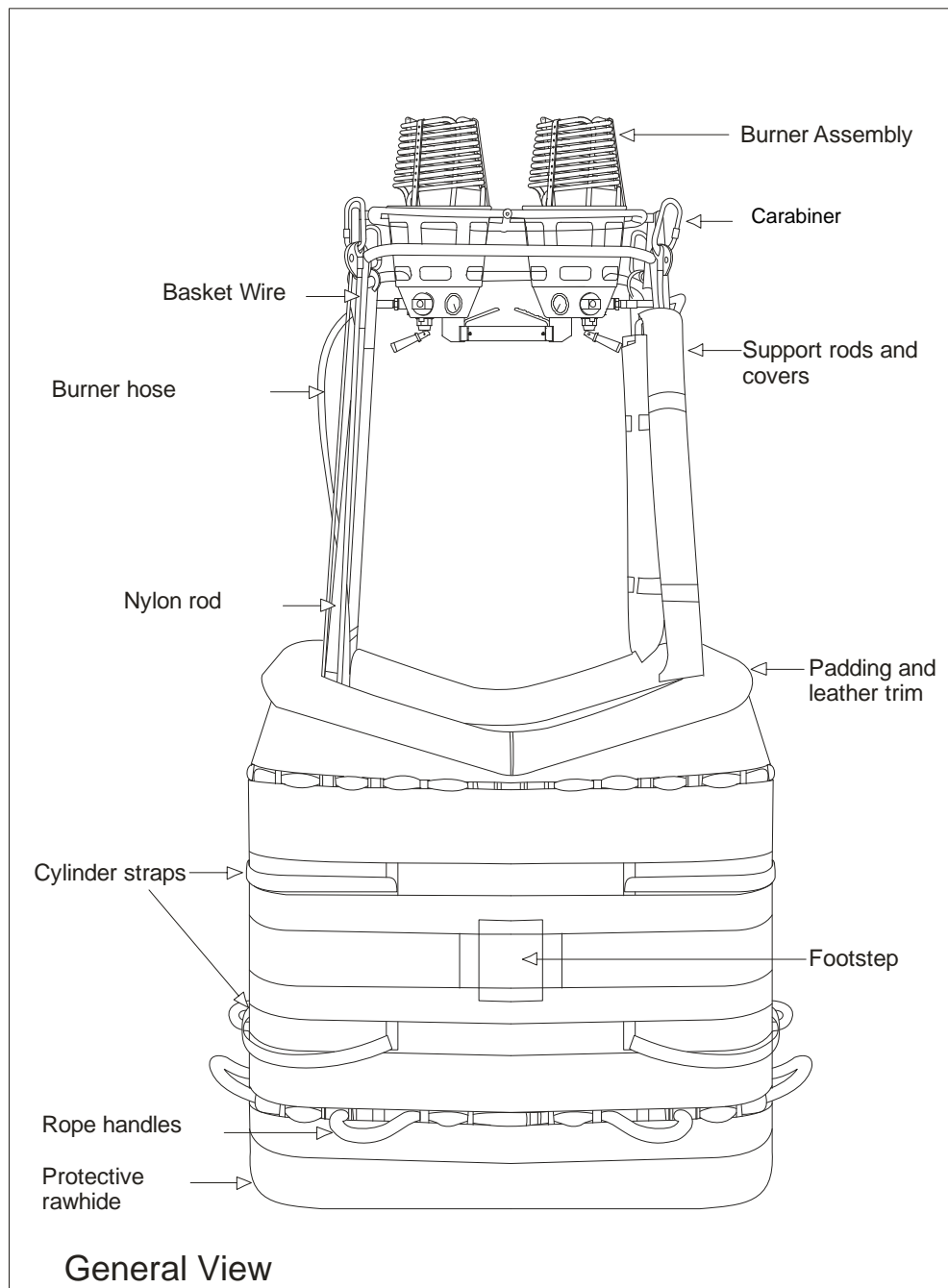

- Check that all fuel lines are in good condition, and then connect them to the cylinders, the vapor feeds (when installed) to the regulators, and the liquid feeds to the main valves.

- Attach the protective covers around the burner supports, making sure that the fuel lines are not pinched by the covers, and that smooth gimbaling of the burner is possible. Check that the fuel lines are not kinked in any way that may prevent the free circulation of fuel or cause increased stress to the fuel system.

- Using a quick release system, attach one end of a rope to the burner frame on the upwind side, and the other end to a vehicle or solid fixed object.

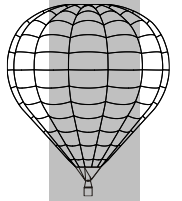

**4
S
T
A
N
D
A
R
D
P
R
O
C
E
D
U
R
E
S**

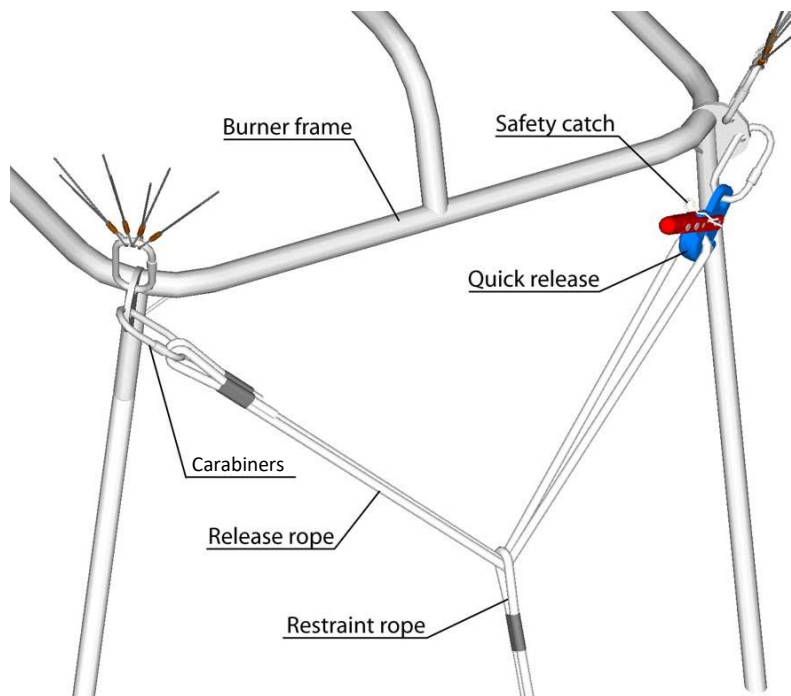

- Prepare the burner for test as described in Section 4.5.3, then lie the basket down on a long side, with the burner pointing downwind. Note that if vapor outlets are being used; ensure that they are uppermost when the basket is laid over. (See below)

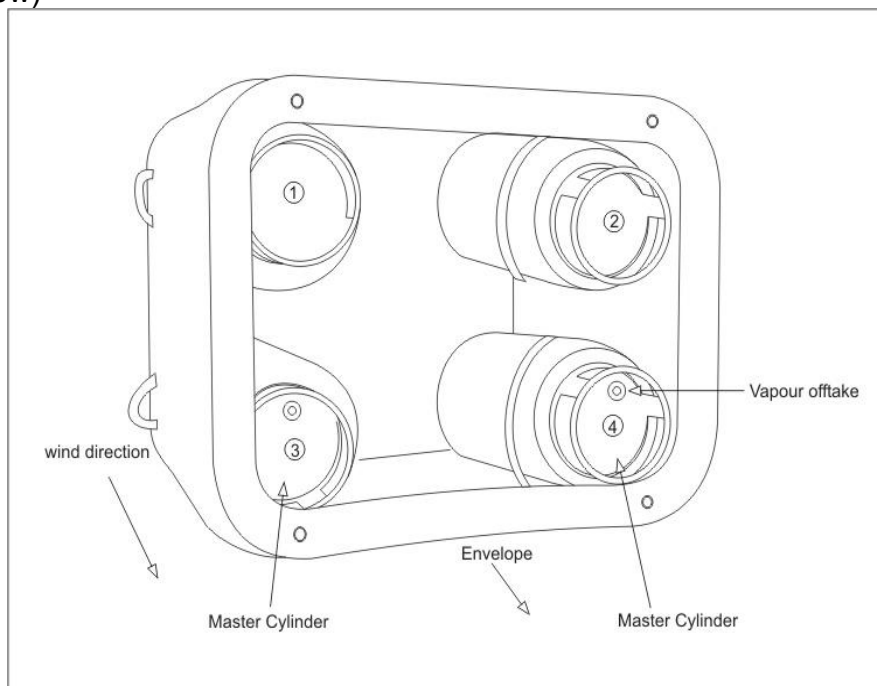

-Note that a T-partitioned basket, the pilot compartment should be on the right when looking from the basket into the mouth of the envelope.

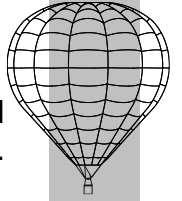

4.5.3 Testing the burner

- With all the burner valves closed, first turn on the liquid fuel supply at the fuel cylinder and then (where applicable) the vapor supply valves at the fuel cylinder. Check that there are no leaks by listening and checking for smell.
- Light the pilot light to one burner, and check the flow, and ensure that the flame is strong. Where a vapor pilot light is fitted adjust the setting of the regulator if required.
- Open the main blast valve on the burner, and check that the flame is burning evenly. Check the pressure gauge reading. This should be between a minimum of 3 bars in winter to a maximum of 10 bar (145 psi) in summer.
- Follow the same procedure for each burner in any configuration.
- Check that the cross-flow valve (when installed) operates correctly (checking 2 or 3 burners that are fuelled from the same fuel cylinder).
- Check that the "quiet" burner operates correctly (when installed).
- If a hydraulic remote control valve is installed, this should be connected and tested. The valve on the burner should open fully when the hydraulic handle is depressed.
- Close the liquid valves on the fuel cylinders, burn the remaining gas in the fuel lines, shut the main blast valve.
- Close the vapor feed valves (when installed) on the fuel cylinders, wait until the pilot light goes out, then close the pilot light valves.

4.5.4 Envelope

- Open the envelope bag and take out the cables and the lower part of the envelope. Find the colored tape sewn to the bottom of the Nomex and place it in the center of the lower part of the envelope. Maintaining this configuration, attach the envelope wires to the load frame with carabiners, making sure they are not twisted towards each other. Cables must be attached as shown in Flying wire connection diagrams.
- A basket fitted with double corner lugs will have two carabiners at each corner. Where a basket has eight poles then there will be a carabiner at the top of each pole. The envelope cables may be connected to a separate set of carabiners. In the case of an eight-pole basket then there should be eight envelope carabiners. Where two adjacent corner lugs are fitted to the load frame, they should not be joined by a single carabiner from the envelope.

The following pages contain different drawings to clarify the position of the red label section on the mouth of the envelope according to the situation of the wires connected to the burner frame.

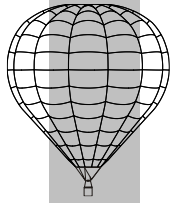

**4
S
T
A
N
D
A
R
D
P
R
O
C
E
D
U
R
E
S**

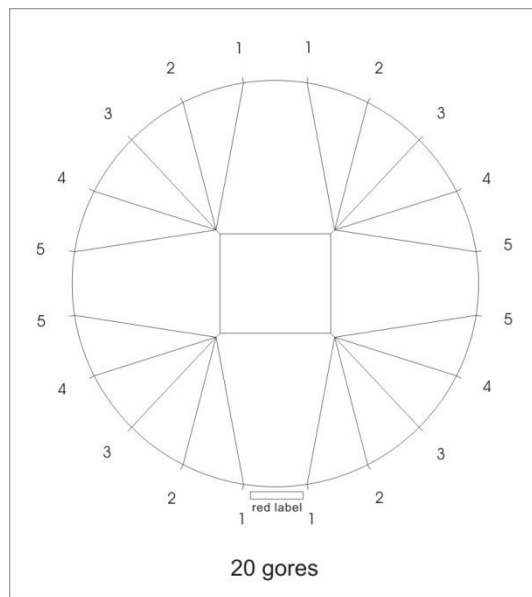
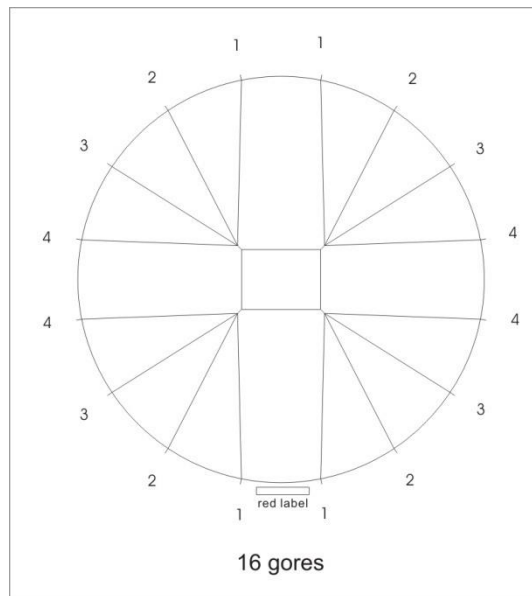
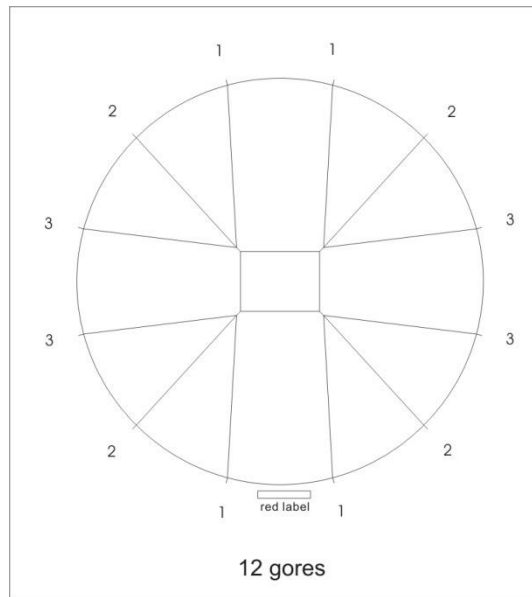

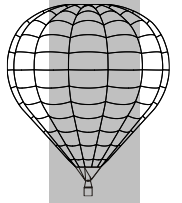

**4
S
T
A
N
D
A
R
D
P
R
O
C
E
D
U
R
E
S**

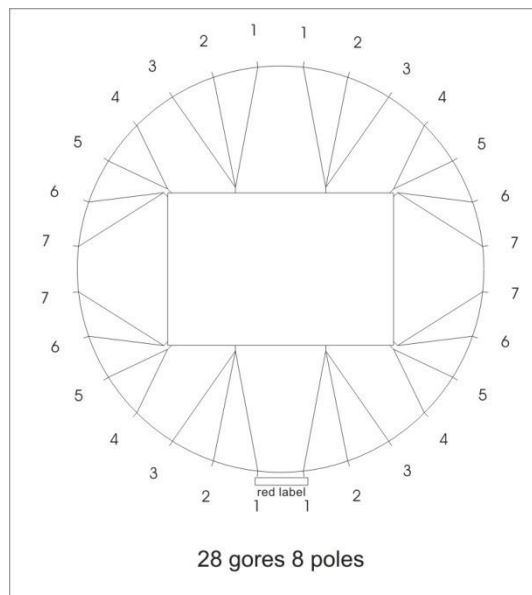
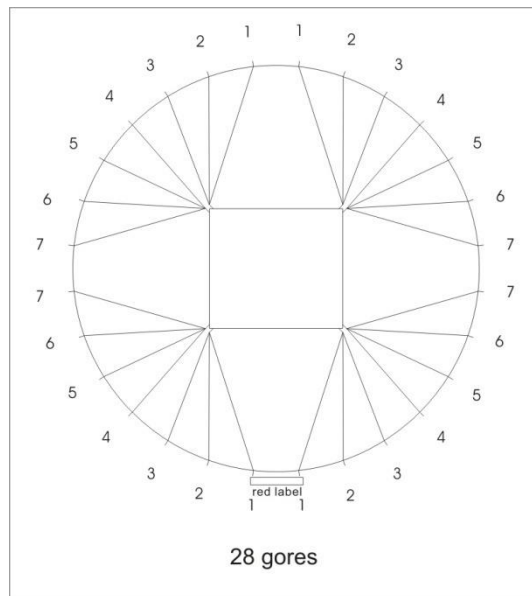
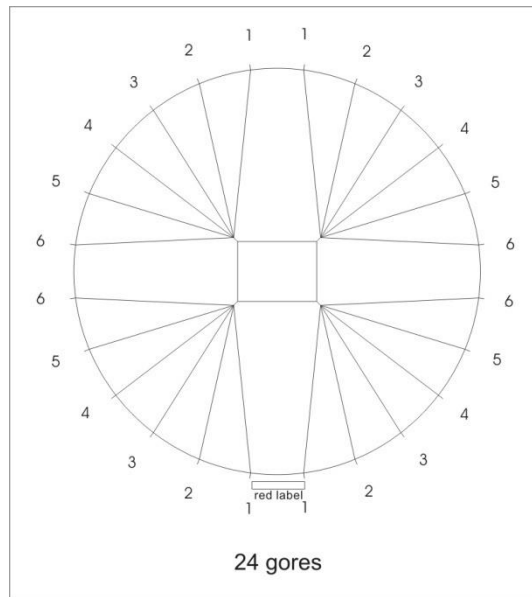

- Close all carabiner screw gates.
- Connect the deflation line to the burner frame.
- Once the envelope is correctly attached, take it out of its bag by pulling the bag downwind.
- Spread the envelope out as much as possible, and lay the crown line out downwind.

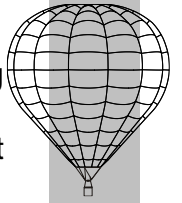

4.6 Deflation system

4.6.1 Parachute

It is easier to carry this operation out at the beginning of cold inflation.

- Check that all lines to the parachute are not tangled.
- Pull at the center of the parachute until it closes against the opening in the balloon.
- Attach the Velcro patches on the edge of the parachute to the corresponding ones on the edge of the balloon opening.

4.6.2 Fast Deflation System (FDS)

- Proceed the same as with a standard parachute system ensuring that all ropes are free from tangles. Check that all lines are free to slide and that no damage can occur.

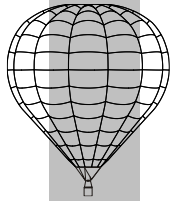

4.7 Inflation

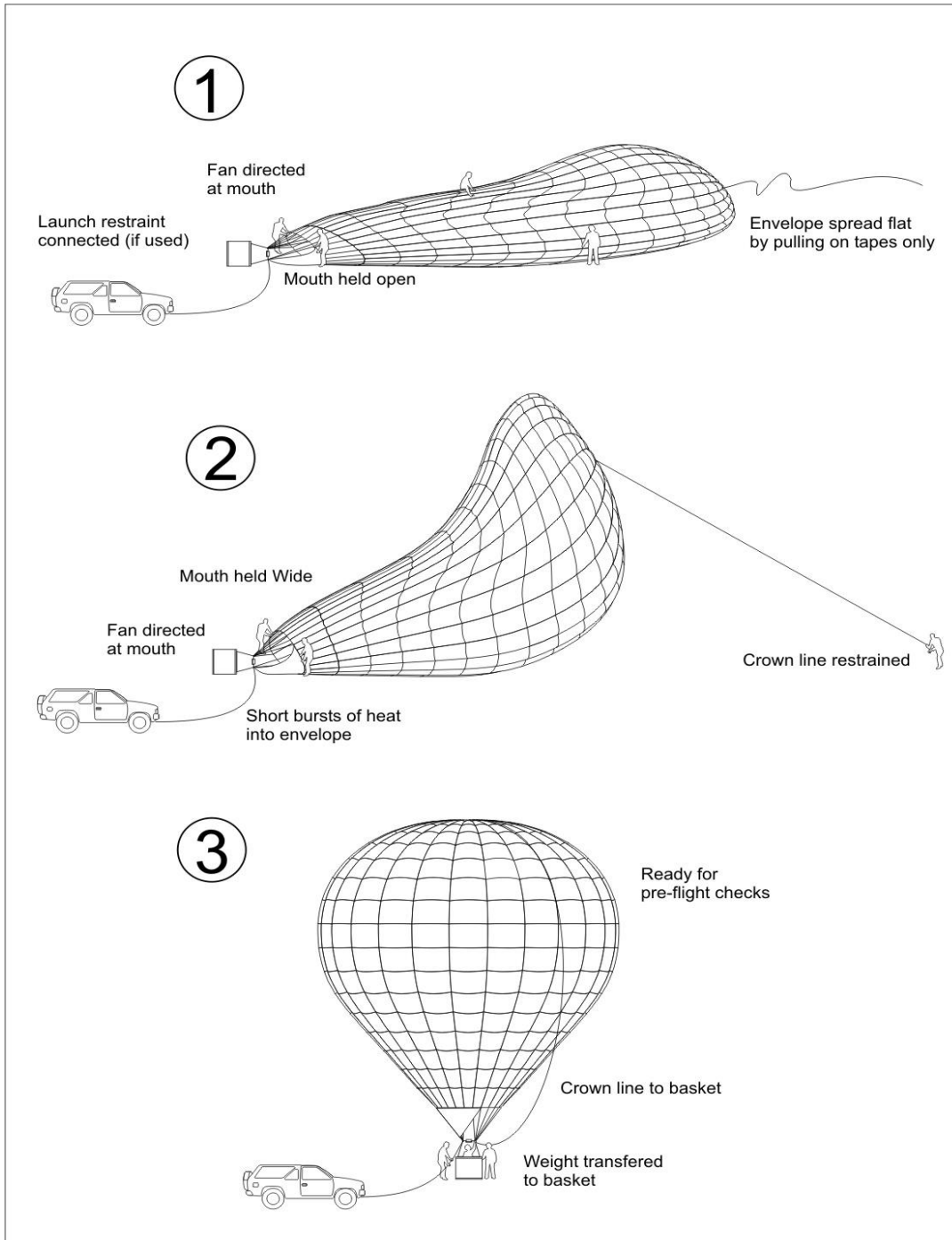

Fill the envelope with cold air using the fan. During this process the mouth is held open by two crew, while one or a maximum of two, keep the crown line taut. When the envelope is as full as possible, inflation is completed using the burner. Light the burner using the procedure in Section 4.5.3. Use only short burner bursts, leaving gaps between burns, to allow the air inside the balloon to be heated slowly and evenly.

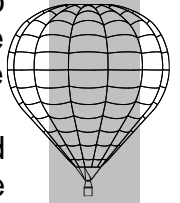

As the balloon inflates, the crew holding the crown line should allow the crown to rise. The fan should be kept running until the mouth of the balloon leaves the ground. It is useful to have a crewmember to angle the fan to direct air into the balloon.

As the balloon becomes upright, the crew on the mouth of the envelope should go and transfer their weight to the basket as the pilot climbs into the basket while the balloon becomes upright.

NOTE: At the pilot's discretion, the crew on the mouth of the balloon may be dispensed with, if the balloon is fully cold inflated.

Also at the pilot's discretion, if the prevailing wind is sufficient to hold the crown down, under the pressure created by the fan, the crown crew may also be dispensed with unless lateral control is necessary.

CAUTION: The crown crew should be made aware of the following instructions.

1. Leather gloves and good grip shoes are advisable.
2. Do not take help from onlookers unless instructed by the pilot as this may create too much force to hold down the envelope resulting in too much lift being generated during inflation.
3. Advise the pilot during cold inflation if problems occur at the top of the envelope.
4. Stay at the end of the rope holding it securely.
5. Do not wrap the rope around themselves.

WARNING: All crewmembers must be instructed that they must not allow their feet to come off the ground during the inflation and pre-flight period while holding either the basket or the crown line. They must let go immediately.

4.8 Preparation for Take off

Checks –

Note: refer also to appendix C.

Once the balloon is upright conduct the following checks:

- Envelope: Check the condition of the fabric, and that there are no tears that would prevent the flight.

- Parachute/Deflating system: Pull the parachute line to release all the Velcro fasteners, making sure it closes properly afterwards and the line are free and correct..

- Carabiners: Screw gates all closed.

- The passengers may now be loaded. The pilot should ensure that each passenger has a handhold and that they have sufficient room. Once the passengers are onboard, they should be briefed. (See 4.8.2 passenger briefing)

Continue checks.

- Pilot light: Normal function and no freezing.
- Burner: Check again that all fuel lines and valves are operating correctly as in Section 4.4.3.
- Fuel: Check the contents of the fuel tanks.
- Equipment: Matches or a lighter, flight instruments.

- Check for downwind obstacles, obstructions and overhead traffic.
- Instruct crew to stand clear.

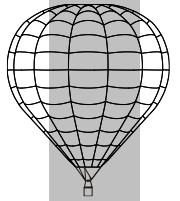

4.8.2 Passenger Briefing

Open Baskets

- Always follow the instructions of the pilot, that will prevail over those here, depending on the landing situation.
- Hold on to rope handles or (except when landing) padded uprights.
- Do not at any time hold on to hoses, valves or control lines.
- When instructed to do so, safely stow all cameras, binoculars etc.
- When instructed to do so, take up the landing position as follows.
 - o Ensure that long hair is safely kept inside cloths or tied back.
 - o Stand at the front of the basket and face the direction of travel.
 - o Keep your knees together and bend them slightly. Do not sit or squat.
 - o Keep hands inside the basket at all times and hold on to the rope handles.
 - o Monitor the landing and brace for touchdown.
 - o Be aware that the basket may tip over and drag after touch down.
 - o Do not leave the basket until the pilot instructs them to do so.
 - o Wear helmets (when necessary)

4.8.2.2 Partitioned Baskets

- Always follow the instructions of the pilot, that will prevail over those here, depending on the landing situation.
- Hold on to rope handles or (except when landing) padded uprights.
- Do not at any time hold on to hoses, valves or control lines.
- When instructed to do so, safely stow all cameras, binoculars etc.
- When instructed to do so, take up the landing position as follows.
 - o Ensure that long hair is safely kept inside cloths or tied back.
 - o Stand squarely with your back against the basket facing away from the direction of travel.
 - o Keep your knees together and bend them slightly. Do not sit or squat.
 - o Press back against the basket wall.
 - o Keep hands inside the basket at all times and hold on to the rope handles.
 - o Monitor the landing and brace for touchdown.
 - o Be aware that the basket may tip over and drag after touch down.
 - o Do not leave the basket until the pilot instructs to do so.
 - o Wear helmets (when necessary)

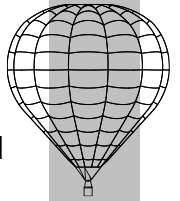

4.9 Take-Off

Take off by increasing the temperature in the envelope with repeated burns, and operate the quick release.

Be ready to use the burner once the balloon has lifted off and stabilized.

WARNING: In low temperature the propane pressure at the burner will be very low, resulting in less burner power and consequently much slower response from the balloon. This may be alleviated by heating or pressurizing the cylinders. Please consult the manufacturer for details.

4.10 Control during flight

4.10.1 Maneuvering in flight

The altitude of the balloon is controlled by the operation of the burner, which is either fully on or fully off. An experienced pilot can judge the length and frequency of burns necessary to control his balloon to within a few centimeters. Remember the maximum ascent rate is 3 m/s (600 ft/min) if no thermometer is being carried.

When a "quiet" burner is installed, it is recommended that this be used below 500 ft, and always in the vicinity of livestock. As it is quieter than the main burner it causes less disturbance, as well as allowing fine control of the balloon.

The parachute may be opened briefly for up to 3 seconds at any one time to increase the descent rate, or halt a climb. Always check to ensure that it has resealed after use. In very lightly loaded conditions a small burn may be required when over-venting has occurred.

WARNING:

The FDS rapid deflation system must never be used above 10 m. (30 ft) from the ground, as this is to be used for final landing only.

The maximum vertical velocity, the altitude drop required to attain that velocity, and altitude drop required to recover from a descent at that velocity are determined in Appendix A for each balloon size.

4.10.2 Fuel management

The burner has two completely separate fuel supplies as an additional safety factor, however only one should be used at any time under normal conditions. The gauges on the top of the fuel cylinders indicate when they are becoming empty, at the same time the sound of the burner will change and the pressure at the burner will drop. If any of those symptoms occur, change the fuel supply to the burner and continue flying on that side until the source of the problem is clear. In order to change fuel tanks, carry out the following procedure:

- Shut off the liquid take-off valve on the empty fuel cylinder.

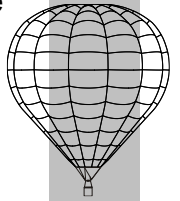

- Open the burner valve until all liquid in the fuel line has been burned, then close the burner valve.
- Disconnect the fuel line from the empty tank and connect it to a full one.
- Open the liquid feed valve on the full fuel cylinder.
- Check that the burner operates correctly from this new supply.

Continue to fly on the new fuel cylinder. When only two cylinders remain, it is advisable to transfer onto the final one leaving about 25% in reserve, so that there is always fuel in both systems.

If a tank is also supplying a vapor pilot light a reserve of approximately 3% per hour of flight must be left for this purpose, and the pilot must be aware that the pressure available to the burner will reduce with time.

4.10.3 Gusting

The balloon may encounter sudden changes in wind speed or direction. This will cause a slight flattening of one side of the balloon until it stabilizes in the new air stream, which causes a loss of volume and lift, together with a sensation of a breeze in the basket. The pilot must compensate for this by burning.

4.10.4 Thermals

WARNING: It is forbidden to intentionally fly in conditions of thermal activity.

However, if thermals are encountered, the internal temperature of the balloon should be maintained as stable as possible, with the balloon at a safe height of over 3,000 ft above ground level until a landing is attempted.

4.11 Landing

Prior to any landing conduct the following checks:

- Burner: Connected, if possible, to a fuel cylinder filled to at least 40% of its capacity.
- Handling line: In light winds, conveniently fastened to the load frame, and ready for easy deployment.
- Rip line in hand during approach
- Passengers briefed.
- The selected landing site is free of obstructions, power lines and animals and is large enough to safely land the balloon in the current weather conditions.

4.11.1 Landing without wind, with parachute

The landing should be made with practically no vertical velocity, the parachute opened immediately after touch down only long enough to stabilize the balloon on the ground.

4.11.2 Landing with wind, parachute

The technique is similar to 4.11.1 but horizontal travel must be minimized to avoid downwind obstacles. To achieve this, a steeper angle of descent is required, rounded out by a long burn to achieve straight and level flight at about 20ft (6 m) above the ground. The parachute is then fully opened until the envelope is fully deflated.

The pilot lights will be extinguished and all cylinder valves should be closed before landing.

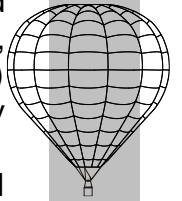

4.11.3 Landing with wind, FDS

When approaching the ground, moderately open the parachute and when arriving at the selected landing place, as fast as possible, open the FDS with the red rope. The FDS should never be used at a height above 10 m (30 ft). The FDS system has the advantage that if the rope is released, the opening remains as it was left. In case of aborting the landing, the white-red line must be pulled to reseal the parachute.

The pilot lights will be extinguished and all cylinder valves should be closed before landing.

4.11.4 Landing Large Balloons.

Care should be taken when landing large balloons (baskets with one side longer than 1.6 m [5.25 ft]) to ensure that the basket is correctly positioned on the approach to allow touchdown on the long side. This is particularly important with partitioned baskets. The basket is correctly positioned by rotating the balloon using the rotation vents. Be aware that the use of the rotation releases hot air while rotating the balloon, be prepared particularly when close to the ground.

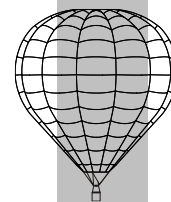
SECTION 5**LOADING****5
L
O
A
D
I
N
G****5.1 Introduction**

For the given volume, the lift of a balloon is limited by the internal temperature. This is affected by the ambient temperature and the altitude of the proposed flight.

This section shows how the Lift is calculated considering all these parameters, without surpassing the maximum authorized load. Maximum Lift takes account of the basket used because it can be lower than the Maximum Lift permitted for the envelope.

5.2 Table of Empty Weight and Maximum Lift

Model	Basket	Pv	Lmax	Model	Basket	Pv	Lmax
H-31	C-0	105/232	307/676	H 42 Vol=12.0	C-0	115/254	373/822
	C-2	110/243	307/676		C-2	120/265	416/917
H 56 Vol=15.9	C-2	146/322	399/879	H 77 Vol=21.9	C-1	158/349	756/1666
	C-0	141/311	549/1210		C-2	155/342	756/1666
H 65 Vol=18.4	C-1	154/340	638/1406		C-3	161/355	756/1666
	C-2	151/333	638/1406		C-10	170/375	756/1666
	C-3	157/347	638/1406	V 56 Vol=15.9	C-2	149/323	549/1210
	C-10	166/366	638/1406		C-0	144/318	402/886
V 65 Vol=18.4	C-1	158/349	638/1406	V 77 Vol=21.9	C-1	162/358	756//1666
	C-2	155/342	638/1406		C-2	159/351	756/1666
	C-3	161/355	638/1406		C-3	165/364	756/1666
	C-10	170/375	638/1406		C-10	174/384	756/1666
V 90 Vol=25.5	C-3	172/380	878/1935	V 105 Vol=29.5	C-4	203/448	1032/2275
	C-1	169/373	878/1935		C-1	181/400	1032/2275
	C-2	166/366	878/1935		C-3	184/406	1032/2275
	C-4	191/422	878/1935		C-10	193/426	1032/2275
	C-10	181/400	878/1935		S 105 Vol=29.5	C-4	198/437
S 90 Vol=25.5	C-3	179/395	878/1935	C-1		176/389	1032/2275
	C-1	167/369	878/1935	C-3		179/395	1032/2275
	C-2	164/362	878/1935	C-10		188/415	1032/2275
	C-4	189/417	878/1935	S 160 Vol=45.5		C-5	307/677
	C-10	179/395	878/1935		C-4	237/523	1569/3459
S 130 Vol=36.8	C-4	215/474	1365/3009		C-6	257/567	1333/2938
	C-1	193/426	1235/2722		C-7	284/627	1569/3459
	C-3	196/433	1365/3009		C-10	227/501	1227/2705
	C-5	285/629	1365/3009				
	C-6	235/519	1321/2912				
	C-7	262/578	1365/3009				
	C-10	205/452	1205/2656				

Model	Basket	Pv	Lmax	Model	Basket	Pv	Lmax
M 42	C-0	124/274	382/842	M 56/M 56c	C-2	146/322	550/1212
Vol=12.0	C-2	129/285	414/912	Vol. 15.9	C-0	141/311	399/879
M 56z	C-1	182/401	549/1210	M 60z	C-1	184/406	588/1296
Vol=15.9	C-2	177/390	549/1210	Vol=17.0	C-2	179/395	588/1296
	C-3	194/428	549/1210		C-3	196/432	588/1296
	C-4	215/474	549/1210		C-4	217/478	588/1296
	C-10	210/463	549/1210		C-10	212/467	588/1296
	CT-01	150/331	549/1210		CT-01	152/335	553/1219
	CT-02	164/362	549/1210		CT-02	166/366	588/1296
	CT-03	153/337	549/1210		CT-03	155/342	588/1296
M 65/M 65c	C-1	159/351	638/1406	M 65z	C-1	200/441	636/1402
Vol=18.4	C-2	156/344	638/1406	Vol=18.4	C-2	195/430	636/1402
	C-3	162/358	638/1406		C-3	212/267	636/1402
	C-4	181/400	638/1406		C-4	233/514	636/1402
	C-10	171/377	638/1406		C-10	228/503	636/1402
					CT-01	168/370	569/1254
M 70z	C-1	203/448	686/1512		CT-02	182/401	636/1402
Vol=19.8	C-2	198/437	686/1512		CT-03	171/377	620/1367
	C-3	215/474	686/1512	M 74z	C-1	209/461	710/1565
	C-4	236/520	686/1512	Vol=21.0	C-2	204/450	710/1565
	C-10	231/509	686/1512		C-3	221/487	710/1565
	CT-01	171/377	572/1261		C-4	242/534	710/1565
	CT-02	185/408	686/1512		C-10	237/522	710/1565
	CT-03	173/381	623/1373		CT-01	165/364	566/1248
M 77/M77c	C-1	161/355	756/1666		CT-02	191/421	710/1565
Vol=22.0	C-2	158/349	756/1666		CT-03	168/370	618/1362
	C-3	164/362	756/1666	M 90	C-10	183/404	878/1935
	C-10	173/382	756/1666	Vol=25.5	C-1	171/377	878/1935
M 105	C-4	205/452	1032/2275		C-2	168/371	878/1935
Vol=29.5	C-1	183/404	1032/2275		C-3	174/384	878/1935
	C-3	186/411	1032/2275		C-4	193/426	878/1935
	C-10	195/430	1032/2275	M 120	C-4	215/474	1173/2586
M 130	C-4	225/497	1365/3009	Vol=34.0	C-1	193/426	1173/2586
Vol=36.8	C-1	203/448	1235/2722		C-3	196/433	1173/2586
	C-3	206/455	1365/3009		C-5	285/629	1173/2586
	C-5	295/651	1365/3009		C-6	235/519	1173/2586
	C-6	245/541	1321/2912		C-7	262/577	1173/2586
	C-7	272/600	1365/3009		C-10	205/452	1173/2586
	C-10	215/474	1205/2656	M 145	C-6	257/567	1333/2938
M 160	C-5	320/706	1569/3459	Vol=41.0	C-3	218/481	1436/3165
Vol=45.5	C-4	250/552	1569/3459		C-4	237/523	1436/3165
	C-6	270/596	1346/2967		C-5	307/677	1436/3165
	C-7	297/655	1569/3459		C-7	284/627	1311/2890
	C-10	240/530	1240/2733		C-10	227/501	1227/2815
N 180	C-5	342/754	1745/3866	N 210	C-8	382/843	2064/4550
Vol=51.0	C-6	292/644	1368/3015	Vol=60.0	C-5	367/810	1936/4268
	C-7	319/704	1607/3542		C-7	344/759	1632/3597
	C-8	357/788	1754/3866		C-9	472/1041	2064/4550
	C-9	447/986	1754/3866		C-11	522/1151	2064/4550
N 250	C-8	405/893	2199/4847	N 300	C-9	522/1151	2680/5908
Vol=70.0	C-5	390/860	1959/4318	Vol=85.0	C-5	417/920	1986/4378
	C-9	495/1092	2408/5308		C-8	432/953	2226/4907
	C-11	545/1202	2408/5308		C-11	572/1262	2924/6446
					C-12	632/1400	2924/6446

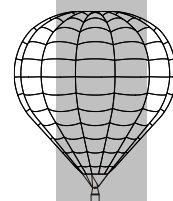

**5
LOADING**

N 355 Vol=100.0	C-9	546/1204	2704/5961	N 425 Vol=120.0	C-12	712/1570	3712/8183
	C-5	491/1083	2010/4431		C-11	652/1438	3332/7345
	C-8	456/1006	2250/4960		C-9	602/1328	2814/6203
	C-11	596/1314	3216/7090		C-5	497/1096	2010/4431
	C-12	656/1447	3450/7605		C-8	512/1129	2250/4960
T 150 Vol=42.4	C-3	231/510	1465/3229	T 180 Vol=51.0	C-5	346/763	1754/3866
	C-10	240/530	1256/2769		C-6	296/653	1372/3024
	C-4	250/552	1465/3229		C-7	323/713	1611/3551
	C-5	320/706	1465/3229		C-8	361/796	1754/3866
	C-6	270/596	1355/2987		C-9	451/995	1754/3866
	C-7	297/655	1465/3229	Z 90 Vol=25.5	C-3	170/375	878/1935
	T 210 Vol=60.0	C-8	376/829		2070/4563	C-1	167/369
C-5		361/796	1930/4254		C-2	164/362	878/1935
C-7		338/746	1626/3584		C-4	189/417	878/1935
C-9		466/1028	2070/4563		C-10	179/395	878/1935
C-11		516/1138	2070/4563	B 40 Vol=11.5	CT-01	83/183	375/827
B 26 Vol=7.4	CT-01	77/170	330/727		CT-03	86/190	375/827
	C-0	97/214	330/727		C-0	97/214	361/796
C-2	110/242	375/827	B 55 Vol=15.5		CT-01	90/198	491/1082
B 50 Vol=14.2	CT-01	88/194		450/992	CT-02	104/229	500/1102
	CT-02	102/225		450/992	CT-03	93/205	500/1102
	CT-03	91/201		450/992	C-0	110/243	368/811
	C-0	108/238		366/807	C-2	122/269	500/1102
	C-2	120/265		450/992	C-1	117/258	500/1102
C-1	115/254	450/992	B 70 Vol=19.8	CT-01	97/214	498/1098	
B 60 Vol=17.2	CT-01	92/203		493/1087	CT-02	111/245	600/1323
	CT-02	106/234		525/1157	CT-03	100/220	550/1323
	CT-03	95/209		525/1157	C-0	117/258	375/827
	C-0	112/247		370/816	C-2	129/284	600/1323
	C-2	124/273		525/1157	C-1	124/273	600/1323
	C-1	119/262		525/1157	C-3	141/311	600/1323
				C-10	157/346	600/1323	

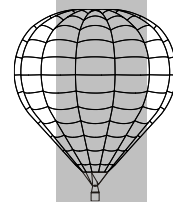

5 LOADING

Vol = Volume in m³x100

Pv = Empty Weight (without any cylinder) (kg/lb)

Lmax = Maximum Lift (Kg/lb) authorized

Note: Pv shall be adapted to the personal configuration of the balloon.

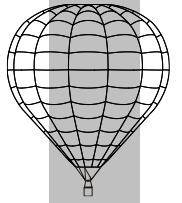

**5
LOADING**

LOADING CHART (International Standard Units)
Envelope temp. 100 °C

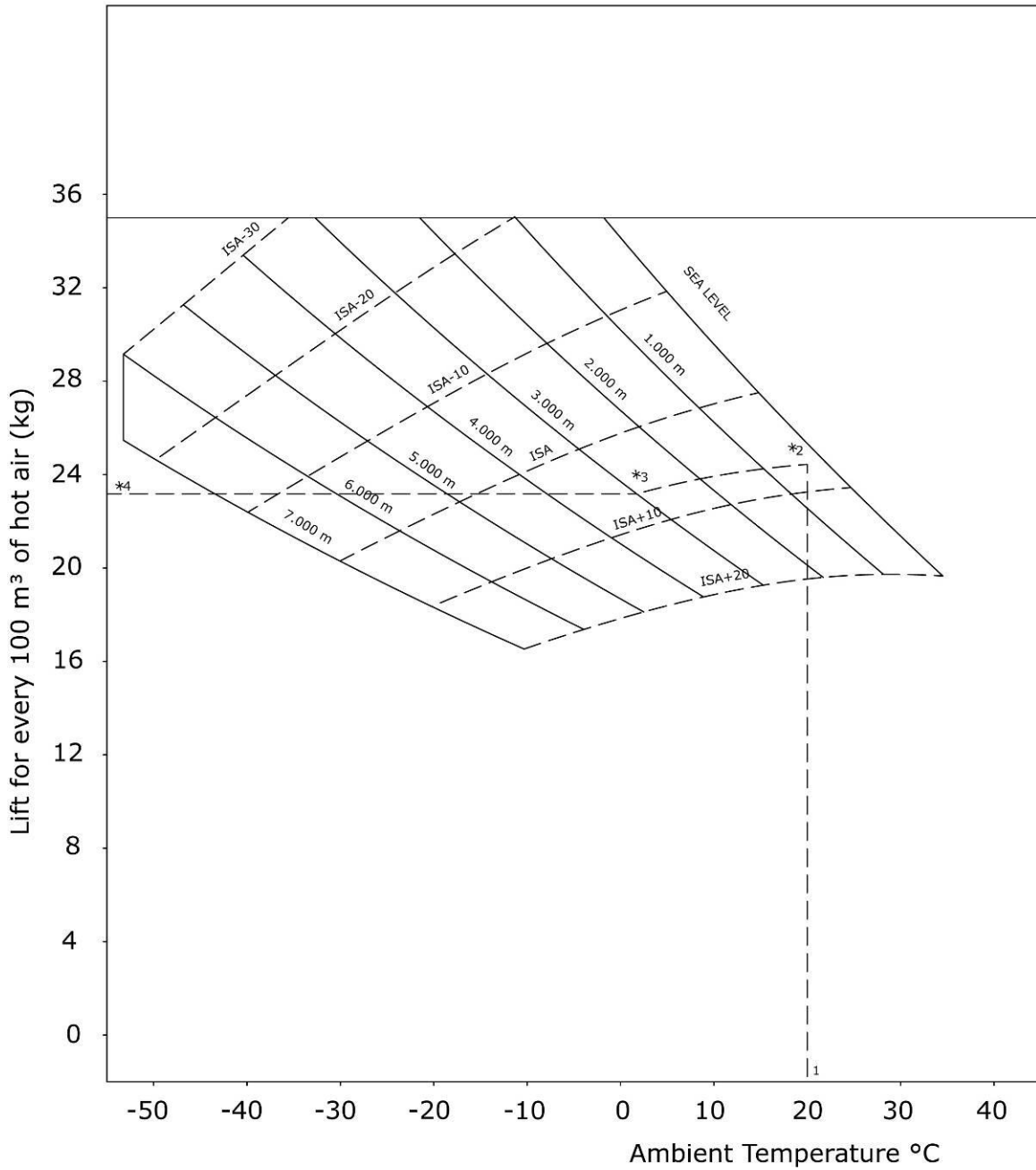

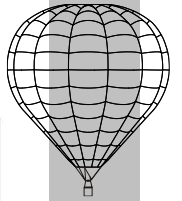

**5
LOADING**

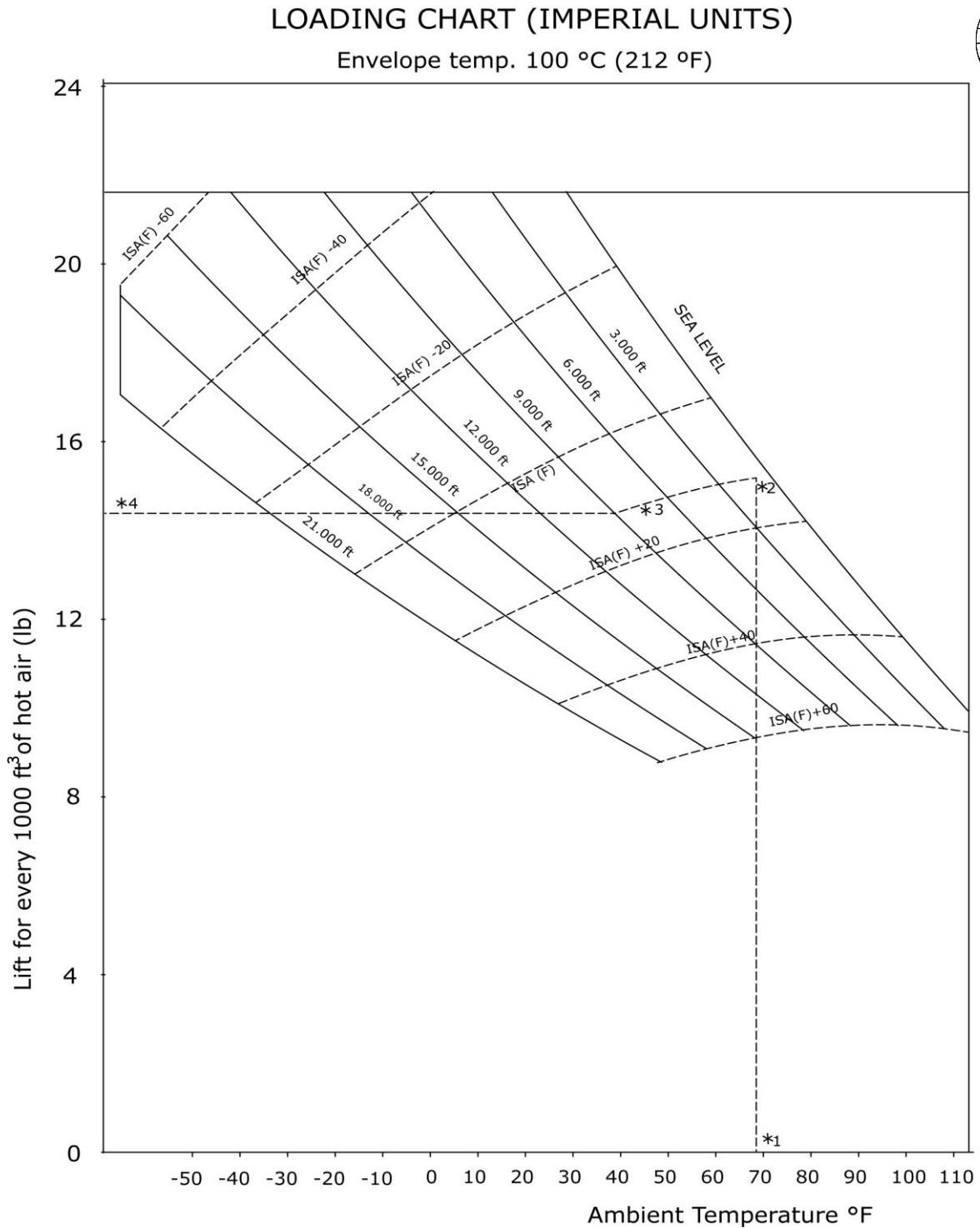

5.3 Load Chart

This graph is used to find the lift available per hundred cubic meters volume at various altitudes and ambient temperature for a temperature of 100° C (212 °F) inside the envelope.

The total payload is the difference between the total lift available and the weight of the various parts of the balloon itself. The empty weight of the balloon does not include empty cylinders or fuel. These should be included in the payload.

See the graphs of pages 5.3 in International System (m) and 5.4 U.S. units (ft).

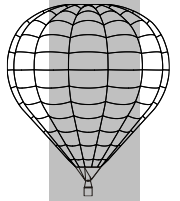

5.3.1 Calculation Example

Flight parameters:

Balloon type H-65

Ambient air temperature: 20° C (68 °F)

Altitude of launch site: 300 m (984 ft)

Maximum altitude planned: 3,000 m (9,842 ft)

1. Starting from the ambient air temperature on the base line (1), follow vertically until the intersection of the 300 m (984 ft) curve (2).
2. From this point trace a curve parallel to the I.S.A. curve to intersect with the 3,000 m (9,842 ft) curve at (3).
3. From (3) trace horizontally across to the vertical axis at (4). Read off 23.2 kg per 100 m³ (14.5 lb/1,000 ft³).
4. The Lift Table of Section 5.2 shows that the H-65 has a V = 18.4 (65 in 1,000 ft³).
5. Total lift in this case is $23.2 \times 18.4 = 427$ kg. ($65 \times 14.5 = 942.5$ lb)
6. Payload = Total lift - empty weight with a C-2 basket
 $= 427 - 151 = 276$ kg ($= 942.5 - 334 = 608.5$ lb ≈ 275 Kg)

These 276 kg (608 lb) have to be distributed between fuel cylinders (minimum 2), fuel, crew, luggage and accessories.

5.4. Table of compatibility

See next pages.

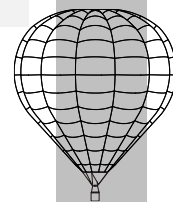

SIZE	31	42	56	65	74/77	90
BURNER MK-2/MK-2 Super MK-10 MK-21 & BMK-008						
SINGLE	*	*	x/§	x/§	x/§	x
DOUBLE			*/§	*/§	*/§	*
TRIPLE						
SILENT	x	x	x	x	x	x
BASKETS						
C0	*	*	☉			
C1			#	*	*	x
C2	x	x	*	x	x	x
C3			#	x	x	x
C4			#	#	#	x
C10			#	x	x	*
CT-01			#	#	#	
CT-02			#	#	#	
CT-03			#	#	#	
ROT. VENTS	x	x	x	x	x	x
FDS	x	x	x	x	x	x
MIN.CYL.	1	1	2	2	2	2

SIZE	105	120	130	145	150	160
BURNER MK-2/MK-2 Super MK-10 MK-21 & BMK-008						
SINGLE	☀	⊗				
DOUBLE	*	*	*	*	*	*
TRIPLE	x	x	x	x	x	x
SILENT	x	x	x	x	x	x
BASKETS						
C1	x	x	x			
C2						
C3	x	x	x	x	x	
C4	*	*	*	*	x	x
C5		x	x	x	x	*
C6		x	x	x	x	x
C7		x	x	x	*	x
C10	x	x	x	x	x	x
ROT.VENTS	x	x	x	x	x	*
FDS	x	x	x	x	x	*
MIN.CYL.	2	2	2	2	2	2

- Standard configuration = *
 - Compatible configuration = x
 - Only MK-21 and BMK-008 = ☀
 - Only BMK-008 = ⊗
 - Only MK-21, BMK-008 and MK-32 for MZ Series = §
 - Compatible configuration except for MZ Series = ☉
 - Only M-56z, M-65z and M-74z = #
- = * (See Notes 1, 2 & 3 below)

Note 1 - Standard configuration for M-56z is BMK-008 Single Burner

Note 2 - Standard configuration for M-65z and M-74z is MK-32 Double Burner

Note 3 - Standard configuration for M-56z is C-1 Basket and for M-74z is CT-02 Basket

SIZE	180	210	250	300	355	425
------	-----	-----	-----	-----	-----	-----

BURNER MK-2/MK-2 Super MK-10 and MK-21 BMK-008 & BMK-050

DOUBLE	X	☀	⊗	⊗		
TRIPLE	*	*	X	☀	⊗	⊗
QUADRUPLE	X	X	*	*	*	*
SILENT	X	X	X	X	X	X

BASKETS

C5	*	*	X	X	X	X
C6	X					
C7	X	X				
C8	X	X	*	X	X	X
C9		X	X	*	X	X
C11		X	X	X	*	X
C12				X	X	*
ROT. VENTS	*	*	*	*	*	*
FDS	X	*	*	*	*	*
MIN.DEP.	2	2	2	2	2	2

SIZE	26	40	50	55	60	70
------	----	----	----	----	----	----

BURNERS

BMK-008 Single	*	*	*	*	*	*
BMK-008 Double				X	X	X
MK-21 Single	X	X	X	X	X	X
MK-21 Double				X	X	X
MK-32 Double				X	X	X

BASKETS

CT-01	*	*	*	X	X	X
CT-02			X	X	X	X
CT-03		X	X	*	*	*
C-0	X	X	X	X	◇	◇
C-1			X	X	X	X
C-2		X	X	X	X	X
C-10					○	X
C-3					○	X
C-4					○	○
MIN.CYL.	2	2	2	2	2	2

- Standard configuration = * (See Note 1 below)
- Compatible configuration = X
- Only MK-21 BMK-008 and BMK-050 = ☀
- Only BMK-050 = ⊗
- Only B-60 and B-70 = ◇
- Only M-60z and M-70z = ○

Note 1 – Standard configuration for M-70z is MK-32 Double Burner

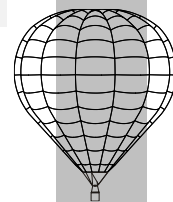

5 LOADING

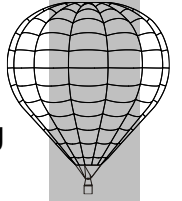

5.5. Minimum Take-off weight

The total take-off weight must never be less than that specified in the following table. This applies to all balloons of Volume greater than 90,000 cu ft.

Explanation note : These values provide for an appropriate internal pressure of the envelope which results in less vulnerability to envelope deformation (loss of hot air) by gusts.

See next page.

VOL (m³) Volume in m³	VOL (ft³) Volume in ft³ x 1,000	Lmax (Kg/lb) Maximum Load in Kg.	Lmin (Kg/lb) Minimum Load in Kg.
3,000	105	1,032/2,275	480/1,059
3,400	120	1,173/2,586	544/1,200
3,700	130	1,365/3,009	588/1,297
4,100	145	1,436/3,165	656/1,447
4,245	150	1,465/3,229	679/1,497
4,550	160	1,569/3,459	728/1,605
5,100	180	1,754/3,866	816/1,799
6,000	210	2,064/4,550	960/2,117
7,000	250	2,408/5,308	1,120/2,470
8,500	300	2,924/6,446	1,360/2,999
10,000	355	3,454/7,614	1,600/3,528
12,000	425	4,140/9,127	1,920/4,233

For MZ Series the following masses must be met at take-off:

Type	M-56z	M-60z	M-65z	M-70z	M-74z
Minimum TO Mass [kg/lbs]	297/655	299/659	303/668	306/675	312/688

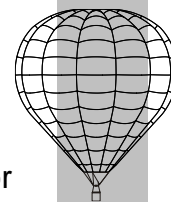

5.6. Reduced Maximum Take-Off Mass Operation

Under certain operational conditions it may be necessary for the balloon operator to select a reduced Maximum Take-Off Mass. Under these circumstances the following limits are advised by Ultramagic S.A.

Envelope Size	Maximum Take-off Mass (kg / lb)	Envelope Size	Maximum Take-off Mass (kg / lb)
26	240 / 529	130	1,235 / 2,722
31	295 / 650	145	1,378 / 3,037
40	350 / 772	150	1,425 / 3,141
42	399 / 879	180	1,710 / 3,769
50	425 / 937	210	1,995 / 4,398
55	475 / 1,047	250	2,375 / 5,235
56	532 / 1,172	315	2,993 / 6,598
60	500 / 1,102	355	3,373 / 7,436
65	618 / 1,362	425	3,995 / 8,807
70	575 / 1,268		
77	732 / 1,613		
90	855 / 1,884		
105	998 / 2,200		
120	1,140 / 2,513		

Approval of these reduced limits must be recorded in the balloon log book by a qualified balloon inspector.

Operational limitations as specified in section 5.2 and 5.5 and all continued airworthiness requirements must be maintained while operating at the reduced Maximum Take-Off Mass.

Normal Maximum Take-Off Mass limitations as section 5.2 and 5.5 can only be restored to the balloon by a qualified inspector making a full inspection of the balloon. This change to the normal MTOM must then be recorded in the balloon logbook by the inspector.

For MZ Series the following reduced MTOM can alternatively be adopted:

Type	M-56z	M-60z	M-65z	M-70z	M-74z
Reduced MTOM [kg/lbs]	531/1171	568/1252	615/1356	663/1462	687/1515

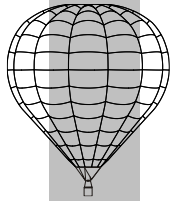

SECTION 6

BALLOON AND SYSTEMS DESCRIPTION

6.1 Introduction

Section 6 provides a description and operation of the balloon and its systems. Optional equipment and systems are detailed in section 9 – Supplements.

6.2 Description

The Hot Air Balloon is remarkably simple in its construction and handling. It consists of three main parts: Envelope, fuel system (burner with load frame and fuel cylinders) and finally a basket.

6.2.1 Envelope

The envelope is composed of a certain number of gores as indicated in the tables of Section 6.3. It is made of high resistance polyamide fabric, reinforced by several polyester load tapes. These load tapes bear forces due to loading, and transmit them via stainless steel cables to the load frame. The lowest part of the envelope is made of heat resistant Nomex.

In the top of the envelope is a large hole, where there is no fabric but the mesh of load tapes continues. This hole is covered, from the inside of the balloon by a loose panel of fabric, centered by a system of cords, which makes it resemble a parachute. It is kept closed by the internal pressure of the balloon, so that it seals tightly against the opening and the mesh of load tapes. It is opened from the basket by pulling a cord, a process that is completely reversible, when the rope is released the parachute reseals.

FDS (Fast Deflation System) is a parachute system but with extra opening capabilities. It's a parachute that can be gathered in the top center pulling the red line, and therefore allowing a great outflow of hot air for fast deflating. The system does not automatically reseal when red rope is released; in this case red/white line must be pulled to close the FDS if necessary. Also pre-flight preparation is similar to a standard parachute system.

The rotation vents are two vertical valves positioned near the equator of the envelope. These are operated independently to cause rotation of the balloon about its vertical axis in either direction.

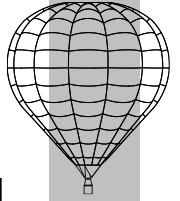

6.2.2 Burner and burner frame.

6.2.2.1 Burner General

The burner is a device for converting the fuel (liquid propane) stored in the fuel cylinders into heat energy. This energy is used to heat the air inside the balloon envelope and thus provide the means of inflation and altitude control during flight.

Fuel is supplied to the burner through flexible hoses. The fuel enters a machined valve block via a fuel inlet post. The fuel is then distributed to the various valves and pressure gauge. Fuel flow is controlled by an on/off valve called the blast or main valve.

Each burner “pot” is fitted with the following major features:

- Burner can.
- Main Burner Vaporizing coil
- Fuel hoses
- Main valve assembly (Blast Valve)
- Liquid valve assembly. (Quiet burner or liquid fire burner valve)
- Pilot regulator valve assembly
- Igniter Assembly
- Pressure gauge assembly.
- Liquid fire jet assembly.
- Pilot light assembly.
- Slurper tube assembly.
- Fuel inlet post.

The burner is available in single, double, triple and quad variants.

A minimum of two blast valves and two fuel supplies are always installed. With a double, triple or quad burner each coil has its own blast valve and fuel supply, while in a single burner both fuel supplies connect to the same burner coil but via separate blast valves.

The main or blast valve allows fuel to pass through the coil to be pre-heated and then burns at the jet or diffuser outlet. This part of the burner gives the maximum power. The blast valve has a squeeze action

The MK-10 burner has a maximum power of 2.5 million Kcal/h (9.92 million btu/h) at a pressure of 6 bar (87 psi), using liquid propane gas.

- 6, 18 or 24 jets or a diffuser to project the vaporized propane.

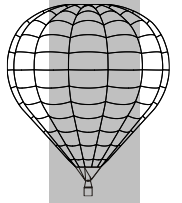

- The Mark 21 Burner gives 2.8 million Kcal/h (11.11 million btu/h) at a pressure of 6 bar (87 psi), using liquid propane gas. The liquid fire or quiet burner valve feeds fuel directly to a multi hole jet assembly without passing through the coil. This valve has a toggle action on the Mk21 and a twist action on the MK-10. This provides less power but a quieter flame for use when flying near animals. This part of the burner is not meant for general use and should not be used to inflate the balloon or when wind shear is present. Excessive use of this burner may cause the inside of the envelope to become black.

Ignition to both blast flames is provided by a pilot light flame. The pilot light is fitted with a shutoff valve and piezoelectric igniter

6.2.2.2 Double, triple and quadruple burners



Double MK-21 Burner

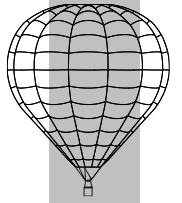

Triple array of the MK-21 Burner



MK-21 Quadruple

6.2.2.3 Load frame

This is a stainless steel frame that establishes the link between the envelope, the burner and the basket. The burner is mounted in the center of the frame by being swivel mounted on a gimbal. The frame is supported on nylon rods, which are fitted into sockets, which are welded to each of the corners of the load frame. The basket and envelope are attached via the load wires to the corners of the frame with carabiners linked to lugs. These lugs are welded to the frame.

6.2.2.4 Hydraulically actuated remote burner valve

The hydraulically operated main valve is an option on the MK-21 burner. This enables the burner valve to be actuated without touching the burner. It does not interfere with the normal valve action of the burner.

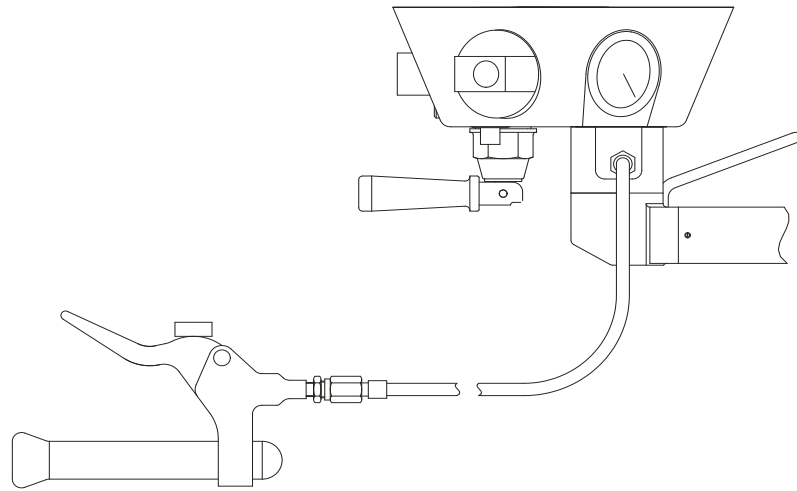

HYDRAULIC MAIN VALVE ASSEMBLY

6.2.3 Basket

The basket is made from woven willow and cane on a marine plywood base. Various openings are woven in to accommodate step holes and strap holes for cylinders.

The basket is connected to the load frame by a minimum of four stainless steel cables that pass down the sides and through and under the base. These cables are continuous in pairs. Tube stiffening and tube sockets are woven in various positions depending on the size and type of basket.

The sockets accept the nylon rods, which support the burner load frame. These support rods, cables and burner hoses are kept inside padded zippered covers when erected.

The floors are reinforced and protected on the outside with hardwood runners, which are bonded and coach bolted to the floor. The bottom edge of the basket, where the wicker joins with the floor, is covered in rawhide for protection from damage.

The top edge of the basket is padded with foam and covered in either leather or suede both to enhance appearance and also to offer passenger protection. The sides of the basket can also be padded and covered on the inside in a hardwearing waterproof canvas type material.

A fire extinguisher is installed in a special padded bag inside the basket.

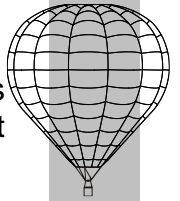

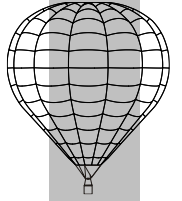

6.2.3.1 Sports Basket



Ultramagic sports baskets are available in various sizes capable of carrying between 1 and 6 passengers. They can be either straight top or swept.

6.2.3.2 Partitioned Baskets



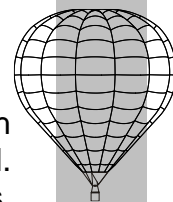

Larger baskets for large balloons are supplied in a number of configurations with various partitioned compartments. These can be T, double T or C partitioned. The pilot and fuel are in a separate compartment separated from the passengers. The sides of the baskets are higher than with the sports basket. The number of support rods and rigging points can also vary depending on the type and size of basket.

As these baskets are considerably longer on one side than the other. The balloon should always be landed on the long side. To achieve this, the envelope should always have rotation vents with a partitioned baskets.

6.2.4 Fuel Cylinders

The fuel (liquid propane) is carried under pressure in cylinders, which are made from aluminum (Worthington) or stainless steel specifically manufactured for Ultramagic. Worthington cylinders have a nominal volume of 40 liters (10 U.S. gal). Ultramagic cylinders are available in sizes of 40, 60 and 80 liters (10, 15 and 20 U.S. gal). These cylinders generally supply liquid propane only and are commonly called slave cylinders. Earlier model burners required a pressure regulated vapor supply also. These cylinders are installed with this valve and regulator are commonly called masters.

Liquid fuel is delivered via a dip tube from the bottom of the cylinder and is controlled by an on/off quick shut off valve. This valve has either a Tema push on connector or a Rego screw on connector for connecting to the burner liquid supply hose.

The pressure regulator for vapor supply is connected to a hand wheel type valve and is opened by turning anti clockwise. The regulator is adjustable and is attached with a push on connector for use with burners where a vapor pilot light is installed.

A contents gauge is installed on all cylinders, which only start to register when reaching the last 25% of fuel contents. A bleed valve is installed with a dip tube, which is used for refueling by volume. A pressure relief valve (PRV) is installed to prevent the cylinders being over pressurized.

The cylinders must be securely strapped vertically in the basket, taking note of the position of the cylinders to be used during inflation. Cylinders to be used for liquid supply during inflation must be positioned so that the liquid valve is in the lower position when the basket is laid on its side. Where a vapor supply is also required the cylinder should be positioned so that the vapor valve is on top when the basket is laid on its side.

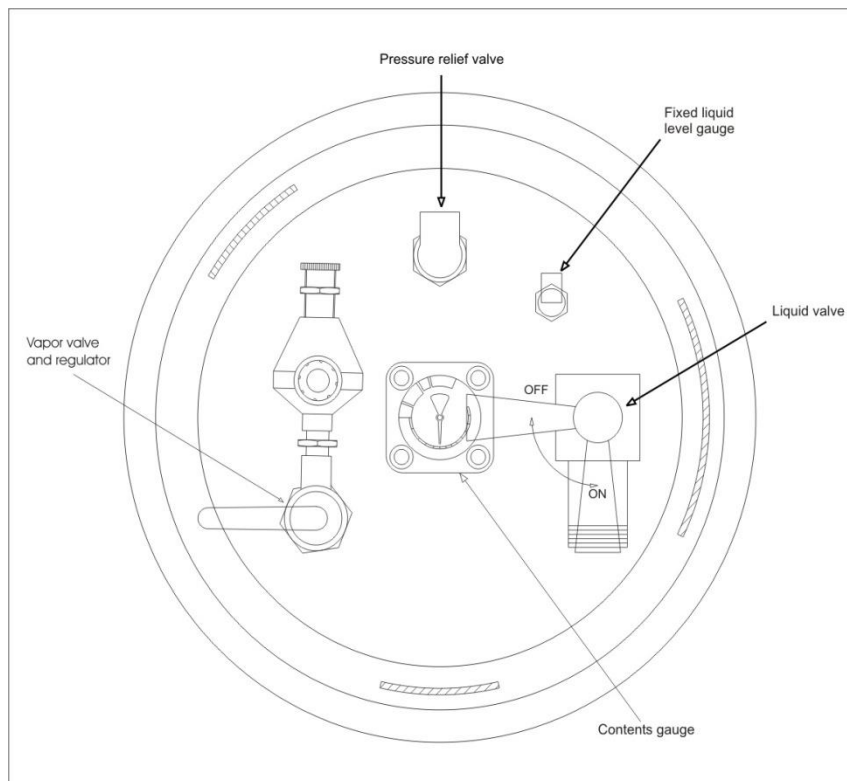
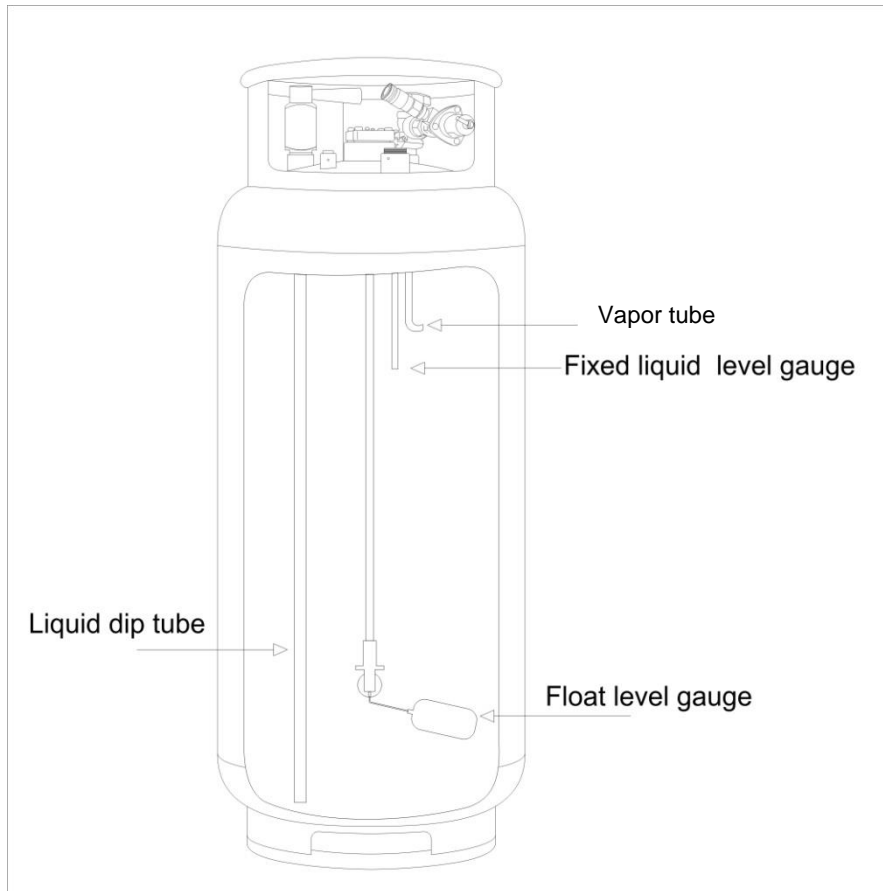
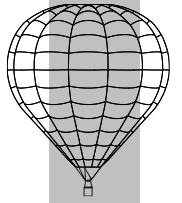

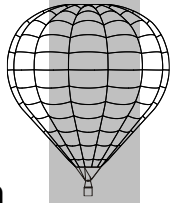

6.2.5 Flight controls

6.2.5.1 Burner Controls

The burner is controlled by an On-Off valve mounted below the burner, and within easy reach of the pilot.

6.2.5.2 Parachute control

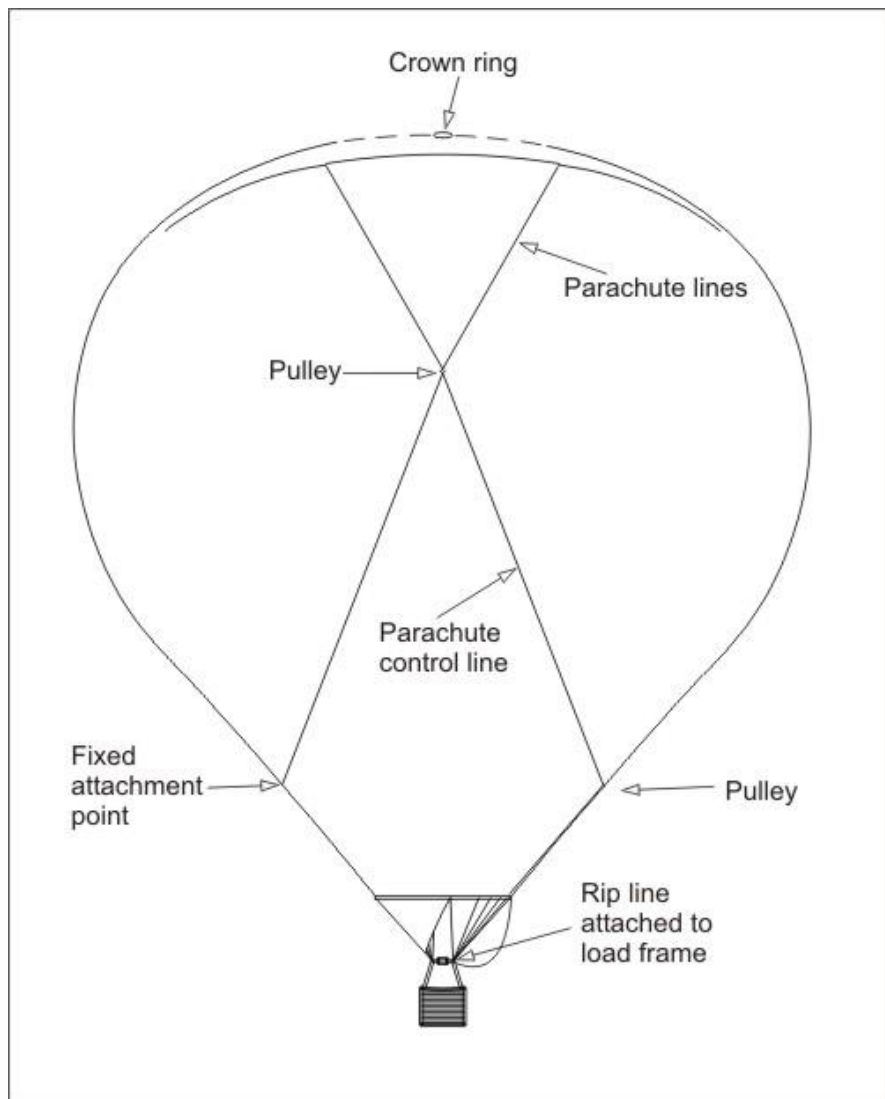

The parachute control line activates the parachute vent or valve. This can either vent off hot air or can totally deflate the envelope. This is the standard method of control on the majority of balloons. The parachute control line is red (or red/white) polyester on the outside with a Kevlar inside, it runs through a pulley inside the envelope to the parachute lines and then back through another pulley and to a fixed point on the inside of the envelope. The pulleys reduce the effort required to open the parachute. By pulling the parachute rip line the parachute is opened. The parachute goes back in place when the line is released after a few seconds. Final deflation is achieved by pulling the line completely and holding until deflated.

6.2.5.3 FDS Fast Deflating control

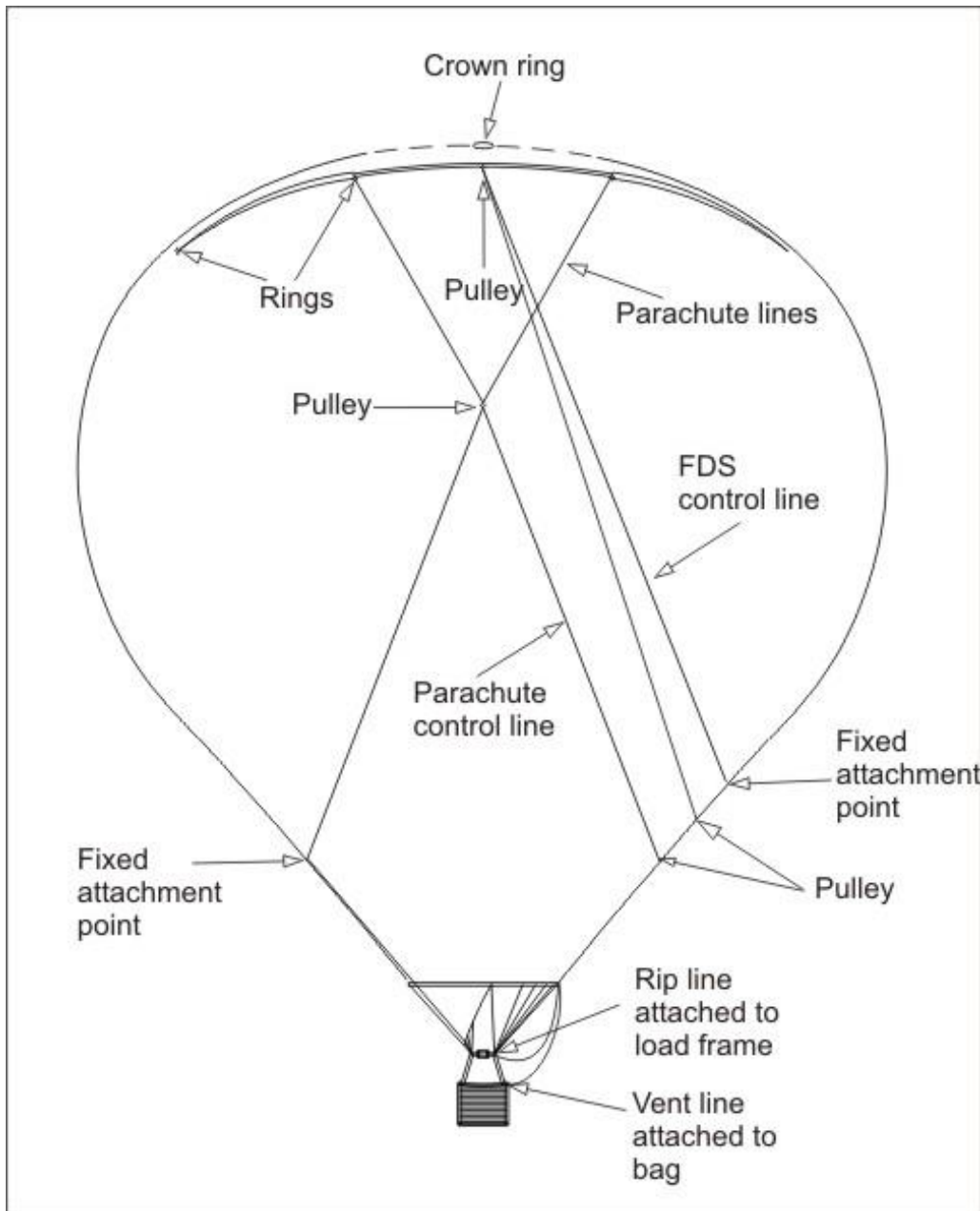
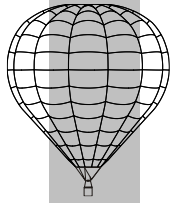

FDS system closed

The FDS system is a rapid deflation system, which incorporates a parachute venting system. The balloon can be vented and deflated as a parachute system by activating the white (or white/red) parachute line. The final rip line, which is red, pulls the center of the parachute together creating a large opening for final deflation. This line must never be used for venting in flight. The opening action of the red rip line (FDS) can be reversed by pulling on the white (or white/red) parachute (vent) line.

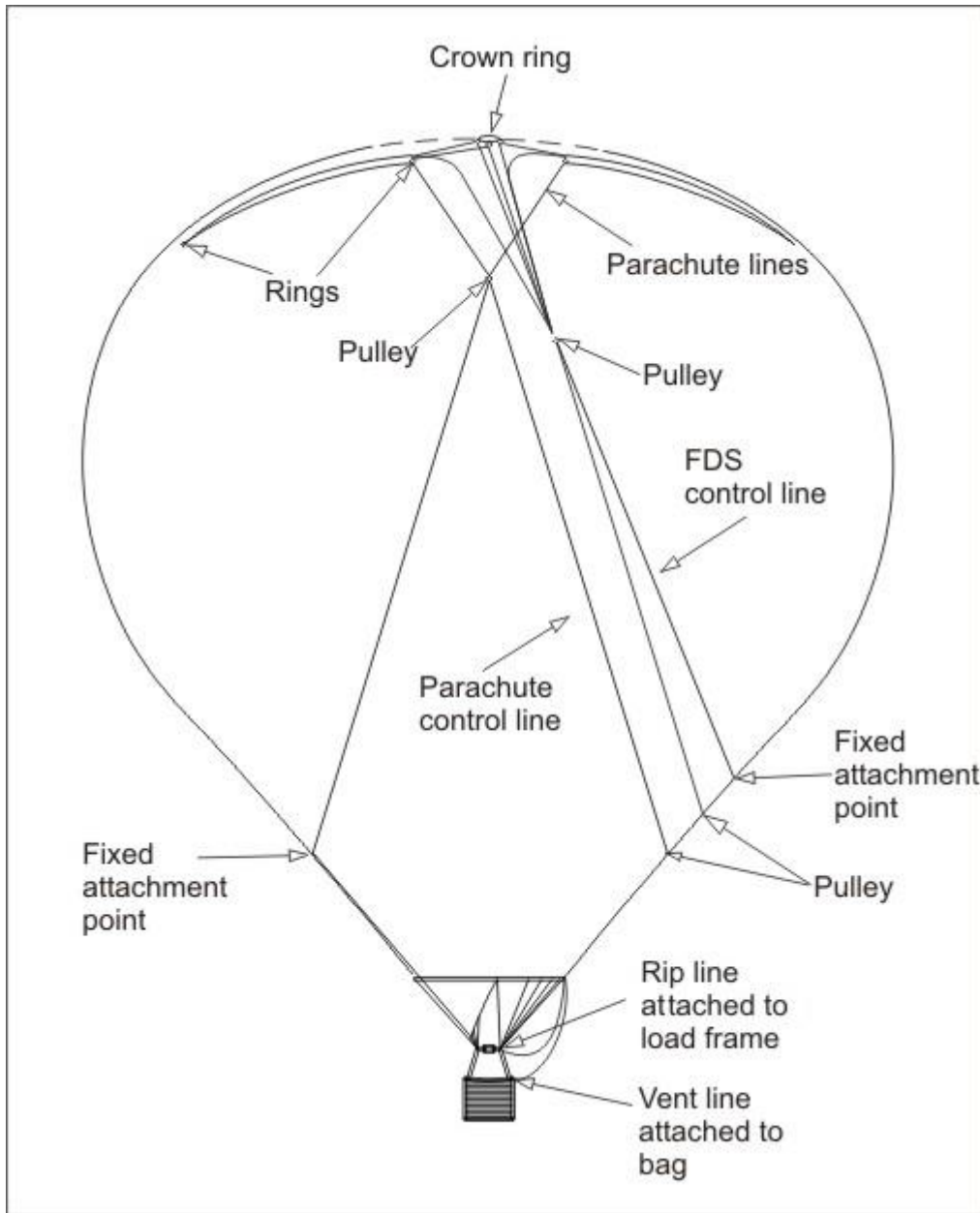
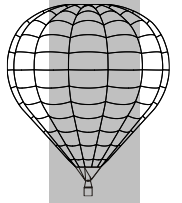

FDS System open

6.2.5.4 Rotation vent control

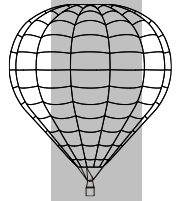
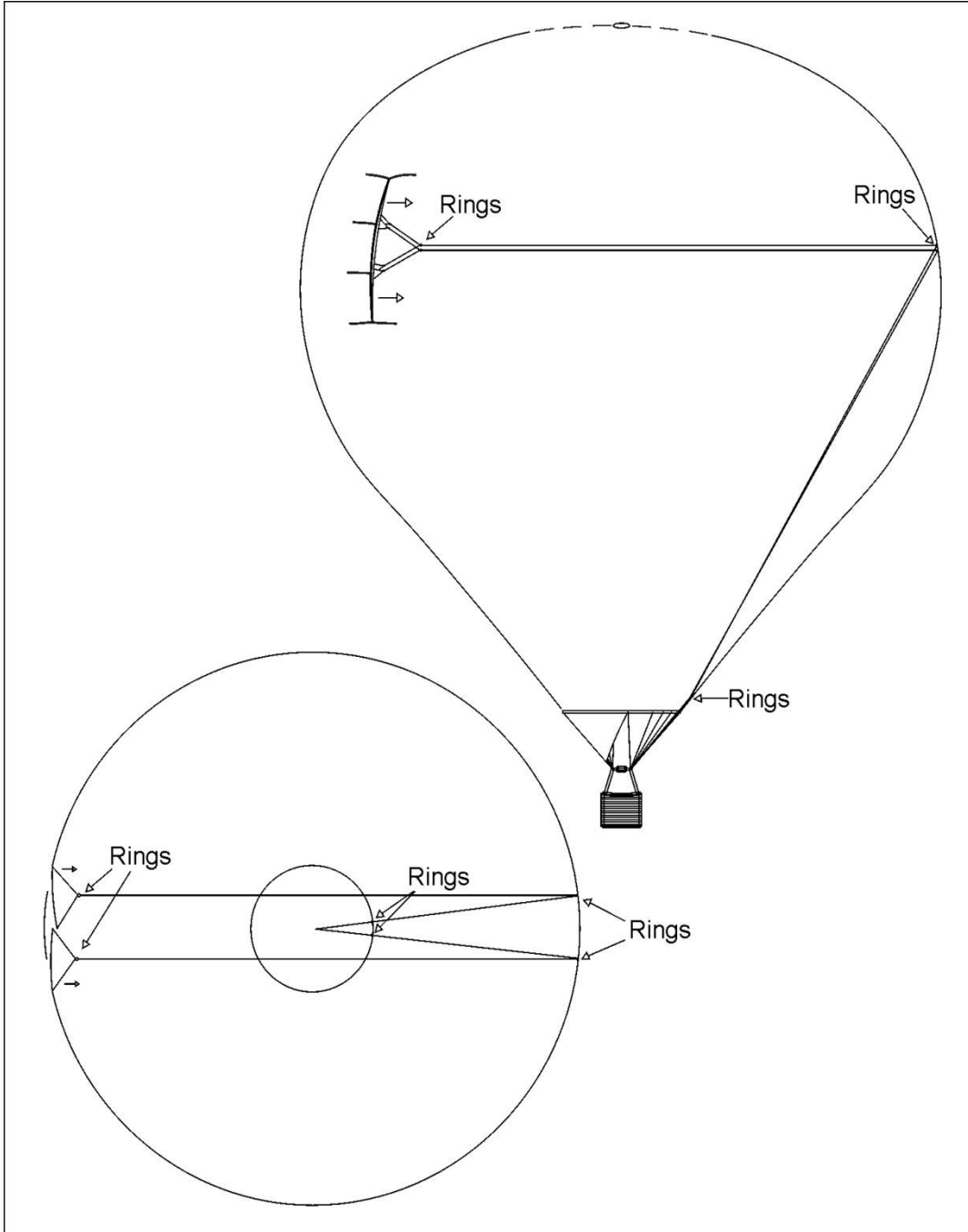

Rotation vents are installed on balloons when it is necessary to rotate the balloon to position the long side of the basket for landing or for general positioning of the balloon. This rotation is about the vertical axis. This is achieved by venting air through a panel near the equator of the balloon. These vents can rotate the balloon in either direction.. The blue line rotates clockwise and the black line counter clockwise. The panel reseals against its overlap panel when the rope is released.

6.3. Dimensions and weights

See following tables

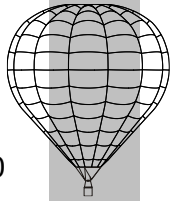

Type	SERIES				
	31	42	56	65	77
Vol. (m ³)	900	1,200	1,590	1,840	2,200
Number of gores	12	12	12	12	12
FAI class	AX4	AX5	AX6	AX7	AX7
Total height (m/ft)	16.2/53.1	17.3/56.7	19.0/62.3	19.9/65.2	20.9/68.5
Standard basket	C0	C0	C2	C1	C1
Weight in Standard configuration. (Kg/lb)	133/293	143/315	174/383	182/401	186/410
Envelope					
Height (m/ft)	12.8/42.0	13.6/44.6	15.0/49.2	16.0/52.5	17.0/55.8
Diameter at the Equator (m/ft)	12.5/41.0	13.8/45.3	15.5/50.8	16.3/53.5	17.3/56.8
Diameter at the Mouth (m/ft)	2.1/6.9	2.8/9.2	3.6/11.8	3.6/11.8	3.6/11.8
Weight (Kg/lb)	51/112	60/132	76/167	85/187	90/198
Parachute					
Diameter (m/ft)	4.0/13.1	4.0/13.1	5.5/18.0	5.5/18.0	5.5/18.0

	SERIES			
	90	105	130	160
Type				
Vol. (m ³)	2,550	2,950	3,680	4,550
Number of gores	16	16	16	16
FAI class	AX8	AX8	AX9	AX10
Total height (m/ft)	21.9/71.8	22.9/75.1	24.5/80.4	26.2/86.0
Standard basket	C10	C4	C4	C5
Weight in Standard configuration. (Kg/lb)	207/456	238/525	255/562	347/765
Envelope				
Height (m/ft)	18/59	18.9/62.0	20.5/67.3	22.1/72.5
Diameter at the Equator (m/ft)	18.2/59.7	19.1/62.7	20.5/67.3	22.1/72.5
Diameter at the Mouth (m/ft)	3.6/11.8	3.8/12.5	3.9/12.8	3.9/12.8
Weight (Kg/lb)	94/207	103/227	120/264	142/313
Parachute				
Diameter (m/ft)	6.0/19.7	6.0/19.7	6.5/21.3	6.5/21.3 FDS

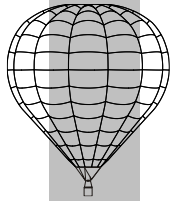

Type	SERIES		V		
	56	65	77	90	105
Vol. (m ³)	1,590	1,840	2,180	2,550	2,950
Number of gores	24	24	24	24	24
FAI class	AX6	AX7	AX7	AX8	AX8
Total height (m/ft)	19/62.3	19.9/65.3	20.9/68.6	21.9/71.9	22.9/75.1
Standard basket (1)	C2	C1	C1	C10	C4
Weight in Standard configuration. (Kg/lb)	177/390	186/410	190/418	209/461	243/536
Envelope					
Height (m/ft)	15/49.2	16/52.5	17/55.8	18/59.0	18.9/62.0
Diameter at the Equator (m/ft)	15.5/50.8	16/52.5	16.6/54.4	17.9/58.7	18.7/61.4
Diameter at the Mouth (m/ft)	3.6/11.8	3.6/11.8	3.6/11.8	3.6/11.8	3.6/11.8
Weight (Kg/lb)	79/174	85/187	89/196	96/212	108/238
Parachute					
Diameter (m/ft)	5.5/18.0	5.5/18.0	5.5/18.0	6.0/19.7	6.0/19.7

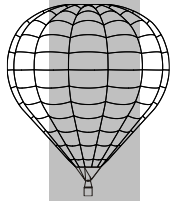

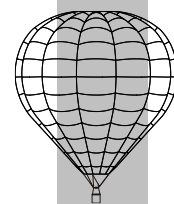

Type	SERIES			M		
	42	56	56c	56z	60z	65
Vol. (m ³)	1,200	1,590	1,590	1,590	1,700	1,840
Number of gores	24	24	24	24	24	24
FAI class	AX5	AX6	AX6	AX6	AX7	AX7
Total height(m/ft)	17.5/57.4	18.8/61.7	21.5/70.5	22/72.2	22.5/73.8	20/65.5
Standard basket	C2	C2	C2	C1	C1	C1
Weight in Standard configuration.(Kg/lb)	152/335	176/388	176/388	182/401	184/406	187/412
Envelope						
Height (m/ft)	14.4/47.2	14.8/48.5	17.3/56.7	18.1/59.4	18.6/61	16/52.5
Diameter at the Equator (m/ft)	13.6/44.6	14.9/48.9	13.8/45.2	13.7/44.9	14/45.9	16/52.5
Diameter at the Mouth (m/ft)	2.8/9.2	3.7/12.1	3.5/11.5	3.4/11.2	3.4/11.2	3.6/11.8
Weight (Kg/lb)	65/143	76/168	80/176	103/227	105/232	86/190
Min. Carabiner (Kg)	-	-	-	3000	3000	-
Parachute						
Diameter (m/ft)	4.0/13.1	5.5/18.0	5.5/18.0	5.5/18.0	5.5/18.0	5.5/18.0
Type						
	65c	65z	70z	74z	77	77c
Vol. (m ³)	1,840	1,840	1,980	2,100	2,200	2,200
Number of gores	24	24	24	24	24	24
FAI class	AX7	AX7	AX7	AX7	AX7	AX7
Total height(m/ft)	22.3/73.1	23/75.5	23.5/77.1	24/78.7	21/68.9	24/78.7
Standard basket	C1	C1	C1	CT-02	C1	C1
Weight in Standard configuration.(Kg/lb)	187/412	200/441	203/448	191/421	189/417	195/429
Envelope						
Height (m/ft)	18/59	19.1/62.7	19.6/64.3	20.1/65.9	17/55.8	19.8/64.9
Diameter at the Equator (m/ft)	14.7/48.2	14.3/46.9	14.7/48.2	15.0/49,2	16.9/55.4	15.5/50.8
Diameter at the Mouth (m/ft)	3.6/11.8	3.4/11.2	3.4/11.2	3.4/11.2	3.6/11.8	3.5/11.5
Weight (Kg/lb)	90/198	109/240	112/247	118/260	88/194	94/207
Min. Carabiner (Kg)	-	3000	3000	3000	-	-
Parachute						
Diameter (m/ft)	5.5/18.0	5.5/18.0	5.5/18.0	5.5/18.0	5.5/18.0	5.5/18.0

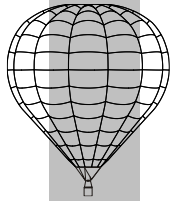

Type	SERIES			M		
	90	105	120	130	145	160
Vol. (m ³)	2,550	2,950	3,400	3,680	4,105	4,550
Number of gores	24	24	24	24	24	24
FAI class	AX8	AX8	AX9	AX9	AX10	AX10
Total height(m/ft)	21.6/70.9	23.1/75.8	23.4/76.8	24.6/80.7	24.7/81.0	26.3/86.3
Standard basket	C10	C4	C4	C4	C6	C5
Weight in Standard configuration. (Kg/lb)	213/470	245/540	255/562	265/584	277/611	360/794
Envelope						
Height (m/ft)	17.6/57.7	19/62.3	19.6/64.3	20.5/67.3	21/68.9	22.1/72.5
Diameter at the Equator (m/ft)	17.4/57.1	18.8/61.7	19.2/63.0	20.2/66.3	19.6/64.3	21.6/70.9
Diameter at the Mouth (m/ft)	3.7/12.1	3.8/12.5	3,8/12.5	4/13.1	4/13.1	4/13.1
Weight (Kg/lb)	98/216	110/242	120/264	133/293	142/313	155/341
Parachute						
Diameter (m/ft)	6.0/19.7	6.0/19.7	6.5/21.3	6.5/21.3	6.5/21.3	6.5/21.3 FDS

	SERIES		N			
	180	210	250	300	355	425
Type						
Vol. (m ³)	5,100	6,000	7,000	8,500	10,000	12,000
Number of gores	28	28	28	28	28	28
FAI class	AX10	AX10	AX11	AX11	AX12	AX12
Total height(m/ft)	27.3/89.6	28.9/94.8	30.3/99.4	32.4/106.3	33.3/109.3	35.5/116.5
Standard basket	C5	C5	C8	C8	C11	C11
Weight in Standard configuration. (Kg/lb)	382/842	407/897	445/981	472/1041	580/1278	635/1400
Envelope						
Height (m/ft)	23/75.5	24.4/80.1	25.5/83.7	27.2/89.2	29.0/95.1	31.2/102.4
Diameter at the Equator (m/ft)	22.5/73.8	23.8/78.1	24.9/81.7	26.6/87.3	27.5/90.2	29.5/96.8
Diameter at the Mouth (m/ft)	4/13.1	4/13.1	4/13.1	4/13.1	4/13.1	4/13.1
Weight (Kg/lb)	168/370	186/410	209/461	236/520	260/573	315/694
Parachute						
Diameter (m/ft)	6.5/21.3 FDS	6.5/21.3 FDS	6.5/21.3 FDS	7.5/24.6 FDS	7.5/24.6 FDS	7.5/24.6 FDS

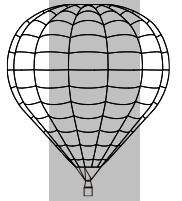

**6
B
A
L
L
O
O
N

A
N
D

S
Y
S
T
E
M
S

D
E
S
C
R
I
P
T
I
O
N**

	SERIES	Z
Type		90
Vol. (m ³)		2,550
Number of gores		16
FAI class		AX8
Total height(m/ft)		21.9/71.9
Standard basket		C10
Weight in Standard configuration. (Kg/lb)		210/463
Envelope		
Height (m/ft)		18/59.1
Diameter at the Equator (m/ft)		18.2/59.7
Diameter at the Mouth (m/ft)		3.6/11.8
Weight (Kg/lb)		94/207
Parachute		
Diameter (m/ft)		6.0/19.7

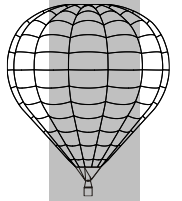

Type	SERIES			T
	150	180	210	
Vol. (m ³)	4,245	5,100	6,000	
Number of gores	20	20	20	
FAI class	AX10	AX10	AX10	
Total height(m/ft)	25.0/82.0	27.3/89.6	28.6/93.8	
Standard basket	C7	C5	C8	
Weight in Standard configuration. (Kg/lb)	350/772	386/851	399/880	
Envelope				
Height (m/ft)	21,23/69.6	22,7/74.5	24,3/79.7	
Diameter at the Equator (m/ft)	20,95/68.7	22,2/72.8	24,3/79.7	
Diameter at the Mouth (m/ft)	4/13.1	4/13.1	4/13.1	
Weight (Kg/lb)	155/342	172/379	180/397	
Parachute				
Diameter (m/ft)	6.5/21.3 FDS	6.5/21.3 FDS	6.5/21.3 FDS	

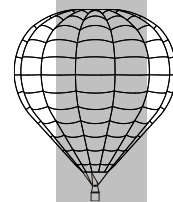

Type	SERIES		B			
	26	40	50	55	60	70
Vol. (m ³)	735	1,143	1,428	1,549	1,715	1,982
Number of gores	12	12	12	12	12	12
FAI class	AX4	AX5	AX6	AX6	AX7	AX7
Total height(m/ft)	17.2/56.4	18.5/60.7	19.8/65	20.2/66.3	21/68.9	21.8/71.5
Standard basket	CT-01	CT-01	CT-01	CT-03	CT-03	CT-03
Weight in Standard configuration. (Kg/lb)	77/169.8	83/183	88/194	93/205	95/209.4	100/220.5
Envelope						
Height (m/ft)	13/42.6	14.3/46.9	15.7/51.5	16.0/52.5	16.8/55.1	17.6/57.7
Diameter at the Equator (m/ft)	11.1/36.4	12.3/40.3	13.9/45.6	14.2/46.6	14.8/48.5	15.6/51.2
Diameter at the Mouth (m/ft)	2/6.6	3.8/12.5	3.8/12.5	3.8/12.5	3.8/12.5	3.8/12.5
Weight (Kg/lb)	30/98.4	36/118.1	41/134.5	43/141	45/147.6	50/164
Min. Carabiner Strength (kg/lb)	450/992	450/992	450/992	450/992	900/1,984	900/1,984
Parachute						
Diameter (m/ft)	4.0/13.1	4.5/14.8	4.5/14.8	4.5/14.8	4.5/14.8	4.5/14.8

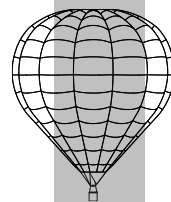

BURNER AND FRAME

Model MK-2	Simple	Double	Triple	Quadruple
Diameter (m/ft)	0.235/0.77	0.235/0.77	0.235/0.77	
D jets (mm/in)	2.0-3.0/0.8-0.12	2.0-3.0/0.8-0.12	2.0-3.0/0.8-0.12	
Total Mass (Kg/lb)	14/30.9	19/41.9	25/55.1	
Model MK-2 Super				
Diameter (m/ft)	0.235/0.77	0.235/0.77	0.235/0.77	0.235/0.77
D jets(mm/in)	1.3-1.7/0.05-0.07	1.3-1.7/0.05-0.07	1.3-1.7/0.05-0.07	1.3-1.7/0.05-0.07
Total Mass (kg/lb)	15/33.1	21/46.3	28/61.7	36/79.4
Model MK-10				
Diameter (m/ft)	0.200/0.66	0.200/0.66	0.200/0.66	0.200/0.66
Diffuser (mm/in)	1-1.5/0.04-0.06	1-1.5/0.04-0.06	1-1.5/0.04-0.06	1-1.5/0.04-0.06
Total Mass (kg/lb)	15/33.1	21/46.3	28/61.7	35/77.2
Model MK-21				
Diameter (m/ft)	0.200/0.66	0.200/0.66	0.200/0.66	0.200/0.66
Diffuser (mm/in)	1.0-1.6//0.04-0.06	1.0-1.6/0.04-0.06	1.0-1.6/0.04-0.06	1.0-1.6/0.04-0.06
Total Mass (kg/lb)	17/37.5	24/52.9	34/75.0	43/94.8
Model PowerPlus BMK-008				
Diameter (m/ft)	0.188/0.62	0.188/0.62		
Diffuser (mm/in)	1.0/0.04	1.0/0.04		
Total Mass (kg/lb)	12/26.4	21/46.3		
Model PowerPlus Maxi BMK-050				
Diameter (m/ft)		0.208/0.68	0.208/0.68	0.208/0.68
Diffuser (mm/in)		1.0/0.04	1.0/0.04	1.0/0.04
Total Mass (kg/lb)		20/44.1	30/66.1	41/90.4

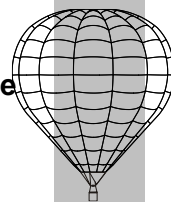

BASKET

Model	C-0	C-1	C-2	C-3	C-4	C-5	C-6
Length (m/ft)	0.7/2.3	1.2/3.9	1/3.3	1.3/4.3	1.6/5.3	2.2/7.2	1.8/5.9
Width (m/ft)	0.8/2.6	1/3.3	1/3.3	1.1/3.6	1.2/3.9	1.4/4.6	1.3/4.3
Height (m/ft)	1.06/3.5	1.10/3.6	1.10/3.6	1.10/3.6	1.15/3.8	1.15/3.8	1.15/3.8
Mass (Kg/lb)	45/99	56/123	50/110	76/168	95/209	160/353	106/234

Model	C-7	C-8	C-9	C-10	C-11	C-12
Length (m/ft)	2/6.6	2.6/8.5	3/9.8	1.45/4.8	3.5/11.5	4.25/13.9 ±0.25/0.8
Width (m/ft)	1.4/4.6	1.5/4.9	1.6/5.3	1.15/3.8	1.7/5.6	1.6/5.3 ±0.1/0.3
Height (m/ft)	1.15/3.8	1.15/3.8	1.15/3.8	1.15/3.8	1.15/3.8	1.15/3.8
Mass (Kg/lb)	122/269	175/386	250/551	85/187	340/750	360/794

FUEL CYLINDERS

Model	43-U4	M 20 M-20D	M 30 M-30D	M 40 M-40D	T-25
Material	Al	Stainless Steel	Stainless Steel	Stainless Steel	Ti
Height (m/ft)	0.87/2.8	0.85/2.8	0.92/3.0	1.07/3.5	0.95/3.1
Diameter (m/ft)	0.30/1.0	0.30/1.0	0.35/1.2	0.38/1.3	0.33/1.1
Empty Mass (Kg/lb)	14/31	15/33	20/44	24/53	11.5/25
Full Mass (Kg/lb)	34/75	35/77	50/110	64/141	36.5/80

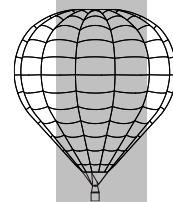

6.4 Monitoring Instruments

6.4.1 Fuel System

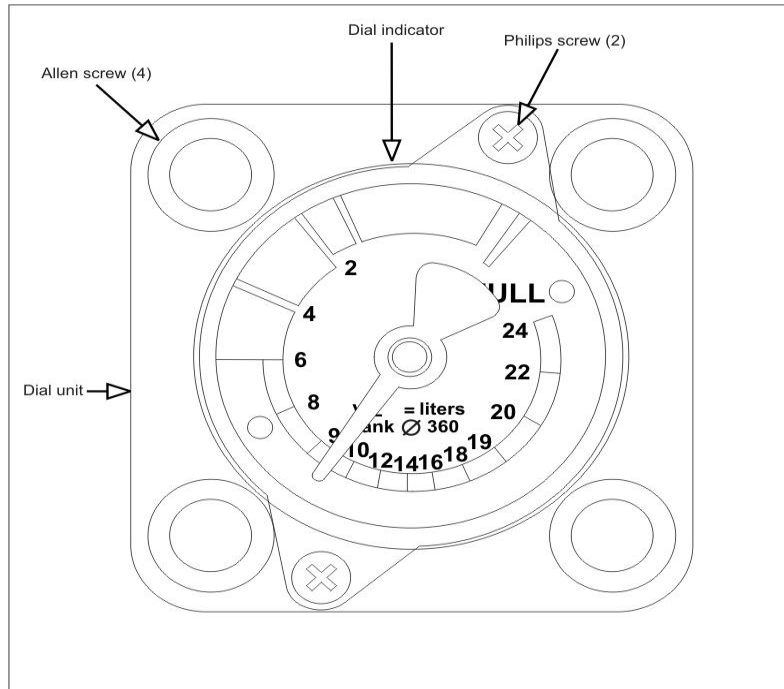
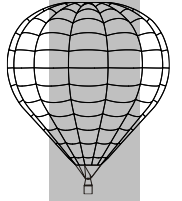

The fuel tanks have gauges in the top showing the percentage of fuel remaining in the tank, below 25%.

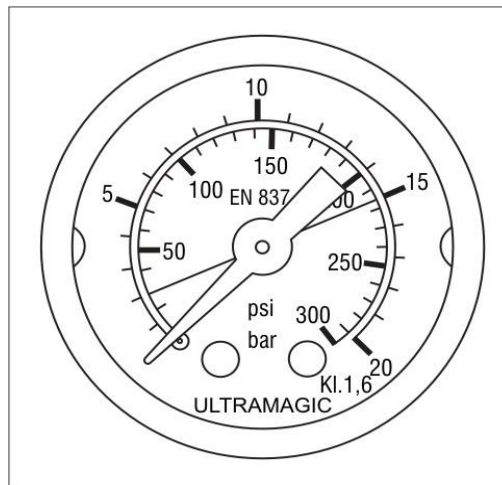

Mk21 pressure gauge

A pressure gauge on the burner indicates the input pressure to the burner.

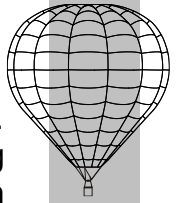

6.4.2 Internal temperature

A soldered link attached to a small flag is located in the upper part of the balloon. Above 125° C (257 °F) the solder melts, releasing the flag, indicating overheating. Alternatively the flag may be held by a bimetallic clamp, which opens at 125° C (257 °F).

A temperature sensor (optional) can be installed on inside top of the envelope that transmits the signal to the indicator on the basket.

A label is placed inside top of parachute, which color changes progressively as the temperature increases.

6.4.3 Flight Instruments.

The requirements for the carrying of flight instruments vary from country to country. The carriage of an altimeter and rate of climb indicator is recommended. In some countries a thermistor is also required for measuring internal envelope temperature during the flight. See Appendix B for a list of instruments recommended by Ultramagic S.A.

6.5 Bonanno Quick Release

This is a device used to restrain the balloon during inflation and preparation for take-off. Its use is recommended during windy conditions to prevent the balloon taking off prematurely or dragging across the ground. However it must not be used to tether the balloon.

The release mechanism is a form of latch, which is attached to the load frame by means of Carabiners and can also be used with wire, rope or webbing bridles. The restraint rope is fitted into the latch and at the other end to a secure point or braked vehicle.

The Bonnano release and all associated restraint equipment must be regularly inspected for damage and deterioration.

6.6 Pilot Restraint Harness

This harness is designed to secure the pilot in position during hard landings. The harness fits around the pilot's waist and is fixed to a restraint harness attachment point on the basket floor. The harness has a special quick release buckle to enable the pilot to remove it in an emergency.

6.7 General illustration

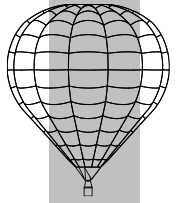

6 BALLOON AND SYSTEMS DESCRIPTION

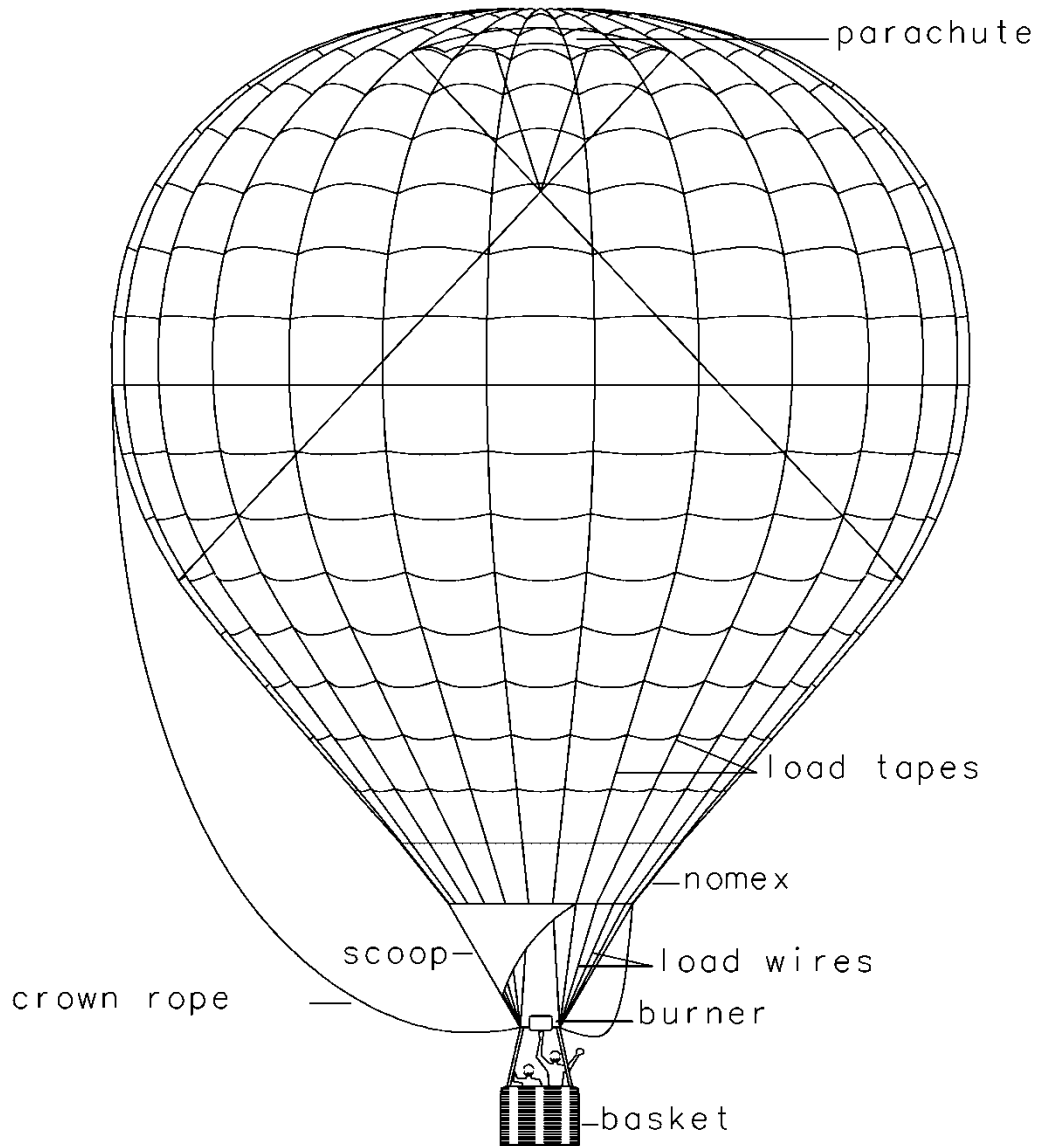

SECTION 7

BALLOON MAINTENANCE HANDLING AND CARE

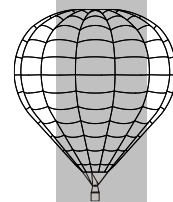

7.1 Introduction

This section contains the recommended procedures for proper ground handling and servicing of the balloon.

7.2 Inspection periods

Refer to the Ultramagic Maintenance Manual for inspection periods

7.3 Alterations or repairs

No alterations to the balloon may be undertaken without first contacting the appropriate airworthiness authority.

WARNING: Any alterations to the balloon without authority approval will invalidate the Certificate of Airworthiness.

Refer to the Ultramagic Maintenance Manual for all repair procedures.

7.4 Ground Handling and Transportation

When not being used the envelope must always be packed for transportation in its protective bag. This will help prevent the fabric from being damaged by sharp or abrasive objects. The envelope in its bag should be prevented from getting wet.

The burner system must be disconnected from the fuel cylinders and all fuel must be vented from the lines.

The basket and burner system must always be de-rigged when being transported. Failure to do so could increase wear on the structure of the support system and load frame.

Whenever possible, fuel cylinders should be transported in a vertical position. Failure to do so may prevent the correct function of the pressure relief valve.

All equipment should be well secured in its means of transport to ensure minimum movement and should also be protected from sharp or abrasive surfaces.

Should the balloon equipment be transported by air, sea or rail it is imperative that the service provider is contacted prior to travel. Each operator has varying requirements relating to the transportation of fuel cylinders, inflation fans and fire extinguishers and these must be planned for and adhered to.

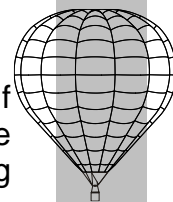

7.5 Storage

The complete balloon system should always be stored in a clean dry place. If stored in an outside utility building e.g. garage or barn, then ensure that adequate protection is in place against possible damage by vermin especially during long periods of storage.

7.5.1 Envelope

The envelope must not be stored wet or damp as the moisture can cause fabric deterioration caused by mold or mildew. Should the envelope have to be packed wet because of weather conditions then the following must be carried out within a few days.

1. Spread the envelope out in a clean dry area.
2. Cold inflate the envelope with an inflation fan and turn the envelope over until completely dry.
3. Ensure that the storage bag is dry before packing the envelope.

CAUTION: Hot inflating a very wet envelope may cause damage to the fabric.

7.5.2 Basket

The basket should always be stored in a clean and dry condition. All mud should be removed as failure to do so may cause damage over a period of time to the wicker, floor and hide. Always use clean water and allow to dry naturally as fast drying may make the wicker brittle and weaken its integrity.

7.5.3 Burner

The burner should always be stored in a clean and dry condition. Ensure that the hose connectors are protected from ingress of dirt. If stored in an outside building it is advisable to cover the burner to prevent foreign matter getting into the jets.

7.5.4 Cylinders

Cylinders should always be stored vertically in a clean and dry condition. This must be a secure place and local regulations must be adhered to.

CAUTION: The valves must always be at the top in their normal operating position. Failure to do so will affect the correct operation of the Pressure Relief Valve (PRV)

CAUTION: Precautions should be taken to ensure that the cylinders do not become over-pressurized. Prevent the cylinders from long periods of direct sunlight or heating.

CAUTION: Do not store cylinders which have been nitrogen pressurized for a long period of time. Vent off the pressure in a safe area if the cylinders are not to be used.

7.6 Cleaning and Care

The envelope should be cleaned using clean water. Avoid the use of strong detergents as these could damage the fabric. A gentle non-detergent soap may be used as long as it is rinsed clean with fresh water. Always ensure that the envelope is dry before packing.

The basket, burner and cylinders may be cleaned using clean water. Always ensure that all systems are dry before storing.

Refer to Ultramagic Maintenance Manual for further cleaning instructions.

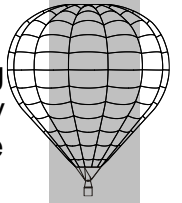

8. OTHER MANUFACTURERS EQUIPMENT

Ultramagic envelopes are approved for use with other manufacturer's equipment as listed in the Supplements below. There is a uniformity of interface between the Ultramagic envelope ranges and the load frames, basket, burners and cylinders listed in the supplements which allows this use. Ultramagic allow this use based on a number of requirements having been met.

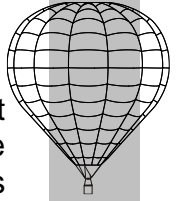

8.1 REQUIREMENTS

To establish compatibility of another basket, burner and tanks from other manufacturers with an Ultramagic envelope, the following conditions must have been met:

- 1) The equipment must be identifiable as an FAA type certified vehicle with the applicable Type Certificate Data Sheet as noted in the supplements listed in section 8.2.
- 2) Other manufacturer's equipment must accomplish all requirements and limitations expressed in the Ultramagic Flight Manual including the supplements.
- 3) The Maintenance Manual for each part remains applicable.
- 4) Other manufacturer's equipment must be on the lists of the Supplements below.
- 5) Weight limitations on the complete balloon are based on the ULTRAMAGIC envelope and also on the basket used, if detailed by the manufacturer, and will be limited by the highest restriction.
- 6) Basket size (length x width = area) must fall within minimum and maximum limits as specified by the manufacturer.
- 7) Burner Type (Single, Double, Triple or Quadruple) must be accomplished as defined by the manufacturer.
- 8) All burner frames with 4 rigging points must be attached with 4 carabiners up to size 180, and 8 or 12 carabiners on bigger envelopes (with the exception of some Lindstrand equipment –see supplement 31-).

8.2 SUPPLEMENTS

Supplement number	Manufacturer	Last update
4 US	Kubicek Balloons	Rev. 17 – Iss. 8
13 US	Raven – Aerostar Balloons	Rev. 2 – Iss. 3
29 US	Cameron Balloons	Rev. 2 – Iss. 4
30 US	Thunder & Colt Balloons	Rev. 17 – Iss. 3
31 US	Lindstrand balloons	Rev. 17 – Iss. 5
33 US	Sky Balloons	Rev. 17 – Iss. 3

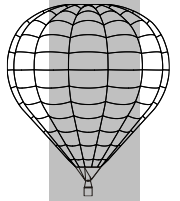

SECTION 9
SUPPLEMENTS

9.1 Introduction

This section contains the appropriate supplements necessary to safely operate the balloon when equipped with various optional systems, equipment and operations not included in the Flight Manual.

9.2 List of Supplements

The following list indicates the Flight manual supplements applicable to the balloon for which this manual is issued. All supplements issued are listed in the following index. Those applicable are ticked and copies of the applicable supplements are included.

All information given in the applicable supplements must be adhered to in addition to information given in the other sections of the Flight Manual.

Balloon Serial Number	Balloon Type	Balloon Registration

Total number of Flight Manual Supplements applicable

Supplement Number	Description	Issue		Applicable
		Num	Date	
1	Tethered Flying	2	08-July-08	
2	Night Flying	2	08-July-08	
4	Kubiček Bottom Ends	8	08-Oct-24	
5	MK-21 Electric Burner	2	08-July-08	
11	Dropping Parachutist	2	08-July-08	
13	Raven-Aerostar Bottom Ends	4	25-July-24	
14	MK-21 Cruise Control Valve	2	08-July-08	
15	MK-21 Burner Butane Fuel	3	08-July-08	
16	Central Gimbal Burner Frame	2	08-July-08	
17	Powerplus BMK-008 Burner	3	08-July-08	
18	Powerplus Maxi BMK-050 Burner	3	08-July-08	
20	Units Conversion Chart	2	08-July-08	
21	MK-21 Burner Vapor Pilot Light	2	08-July-08	
25	Special Shapes U.S. approved	1	08-July-08	
29	Cameron Bottom Ends	5	25-July-24	
30	Thunder & Colt Bottom Ends	4	08-Oct-24	
31	Lindstrand Bottom Ends	5	08-Oct-24	
33	Sky Bottom Ends	3	08-Oct-24	
34	Envelope N-500 & Basket C-14	1	21-Aug-18	
38	"Tekno" Envelopes	2	28-May-14	
39	"Tekno" Baskets	7	09-Feb-24	
43	Special Shape F-35 "R4TS"	1	21-Sep-12	
48	CV "Vista" Baskets	2	09-Feb-24	
50	MK-32 Burner Series	3	27-May-16	
51	MK-32 Burner Series w/ Oxygen Pilot Light	2	27-May-16	

APPENDIX

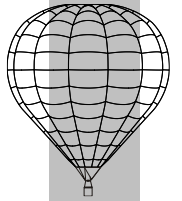

A. Descent Rates and Altitude recovery (Metric units)

**A
D
E
S
C
E
N
T

P
E
R
F
O
R
M
A
N
C
E
S**

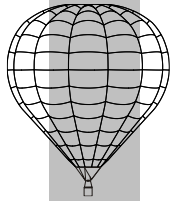

**A
D
E
S
C
E
N
T
P
E
R
F
O
R
M
A
N
C
E
S**

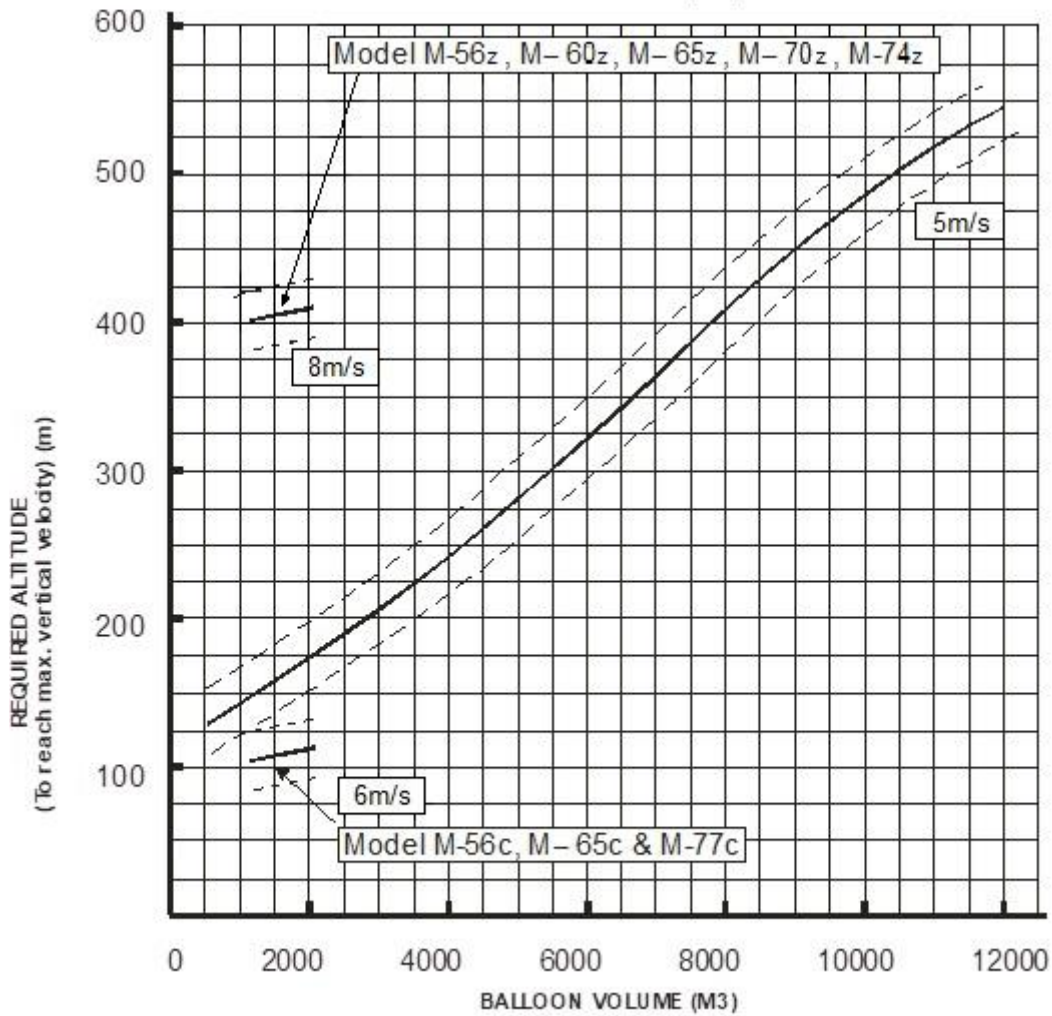
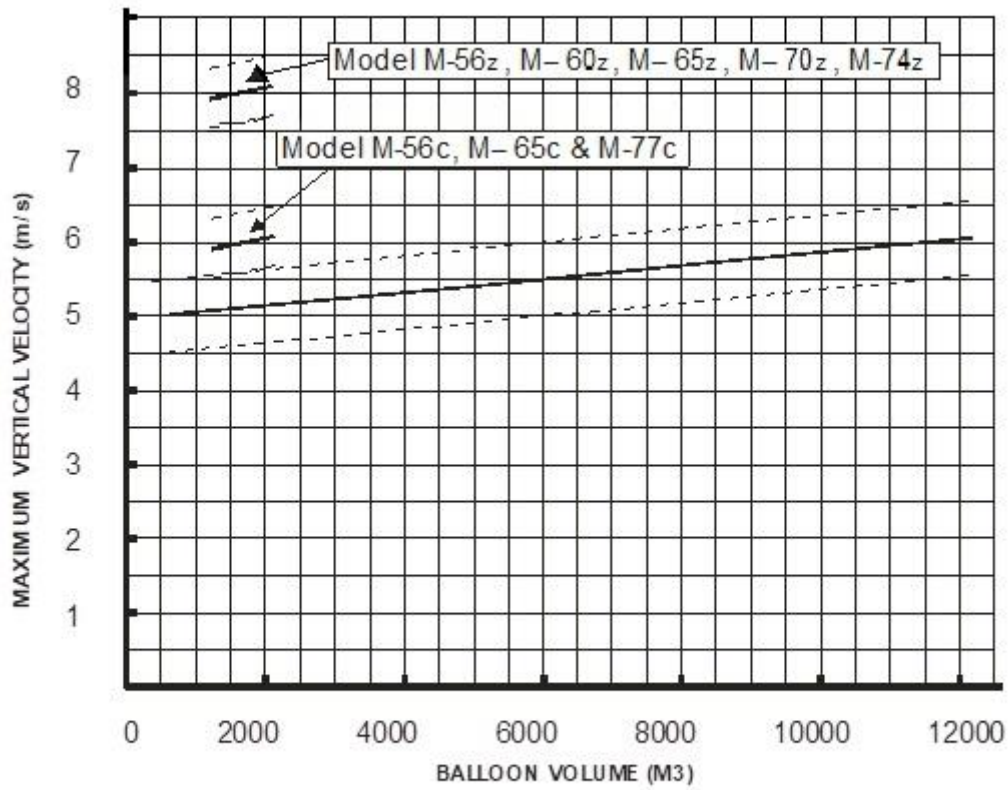

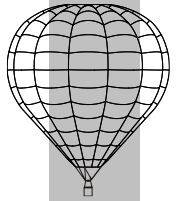

SIZE 70 - 60

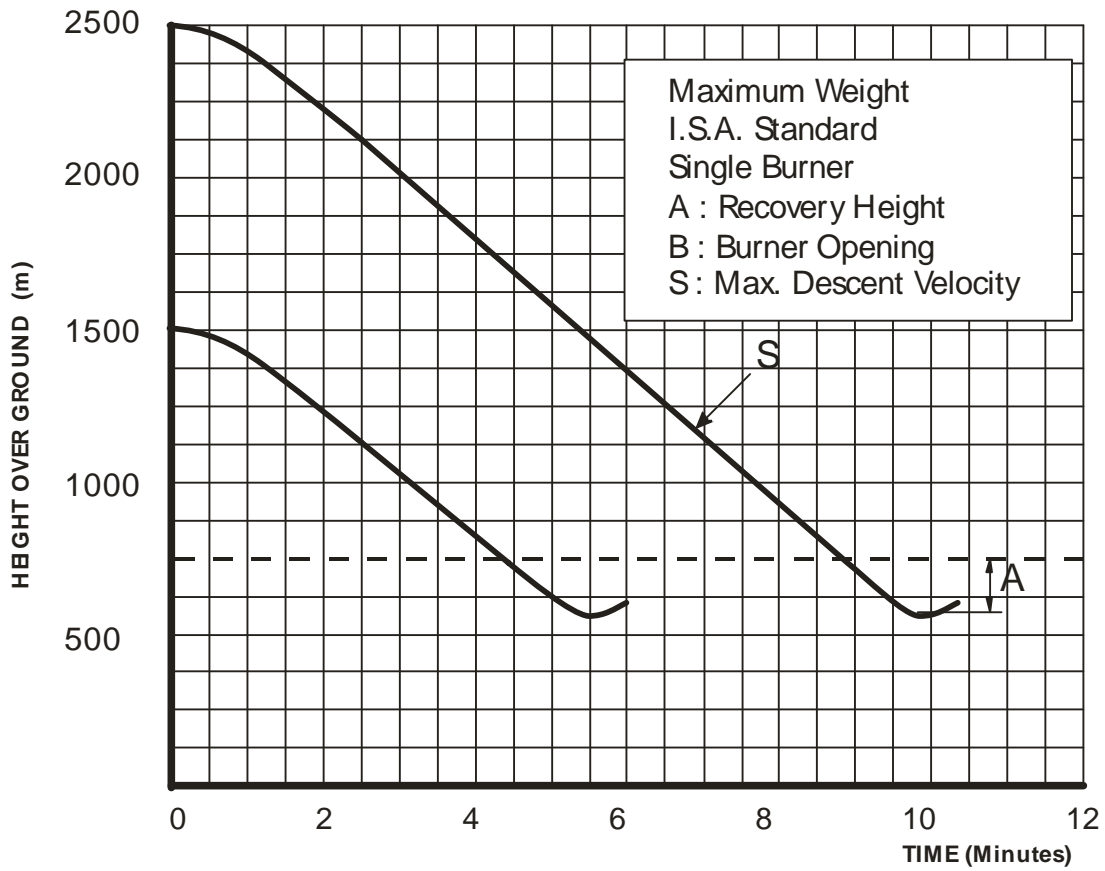

SIZE 26 - 55

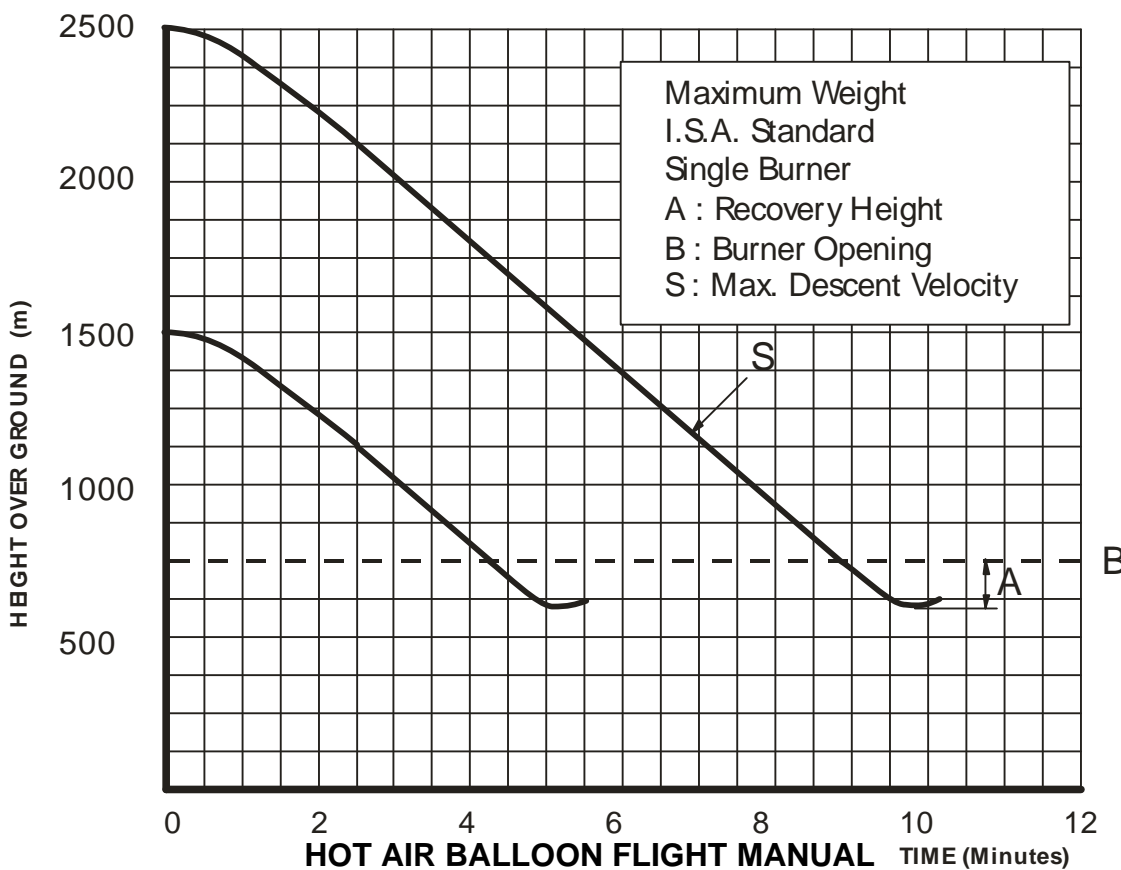

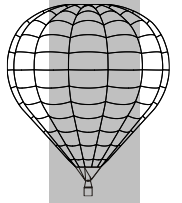

**A
D
E
S
C
E
N
T
P
E
R
F
O
R
M
A
N
C
E
S**

SIZE 31 (900 m3)

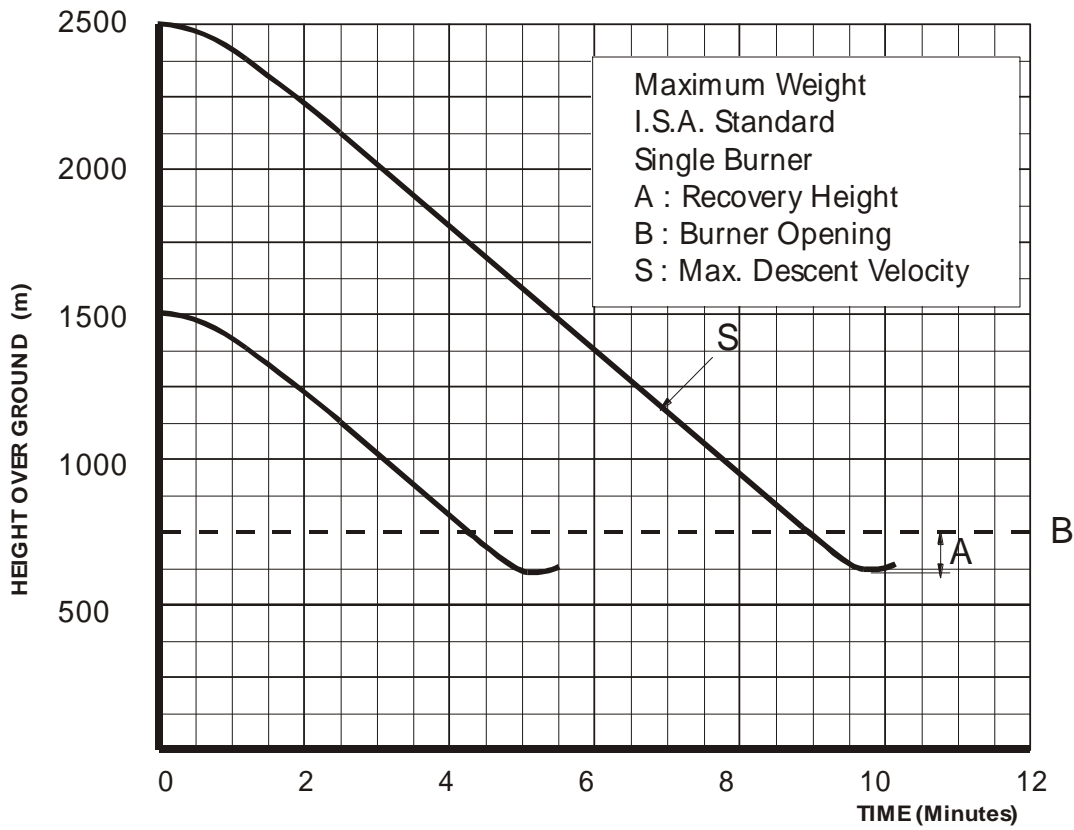

SIZE 42 (1200 m3)

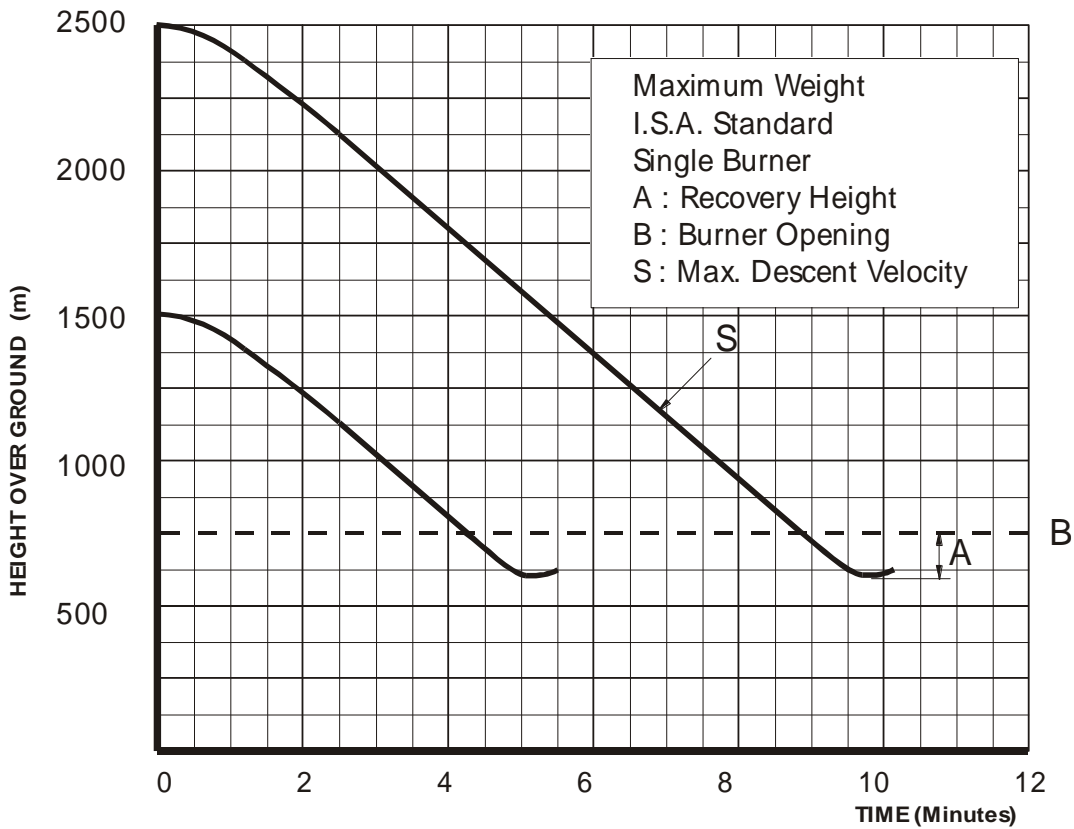

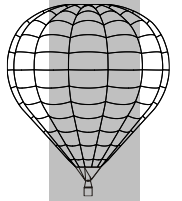

**A
D
E
S
C
E
N
T
P
E
R
F
O
R
M
A
N
C
E
S**

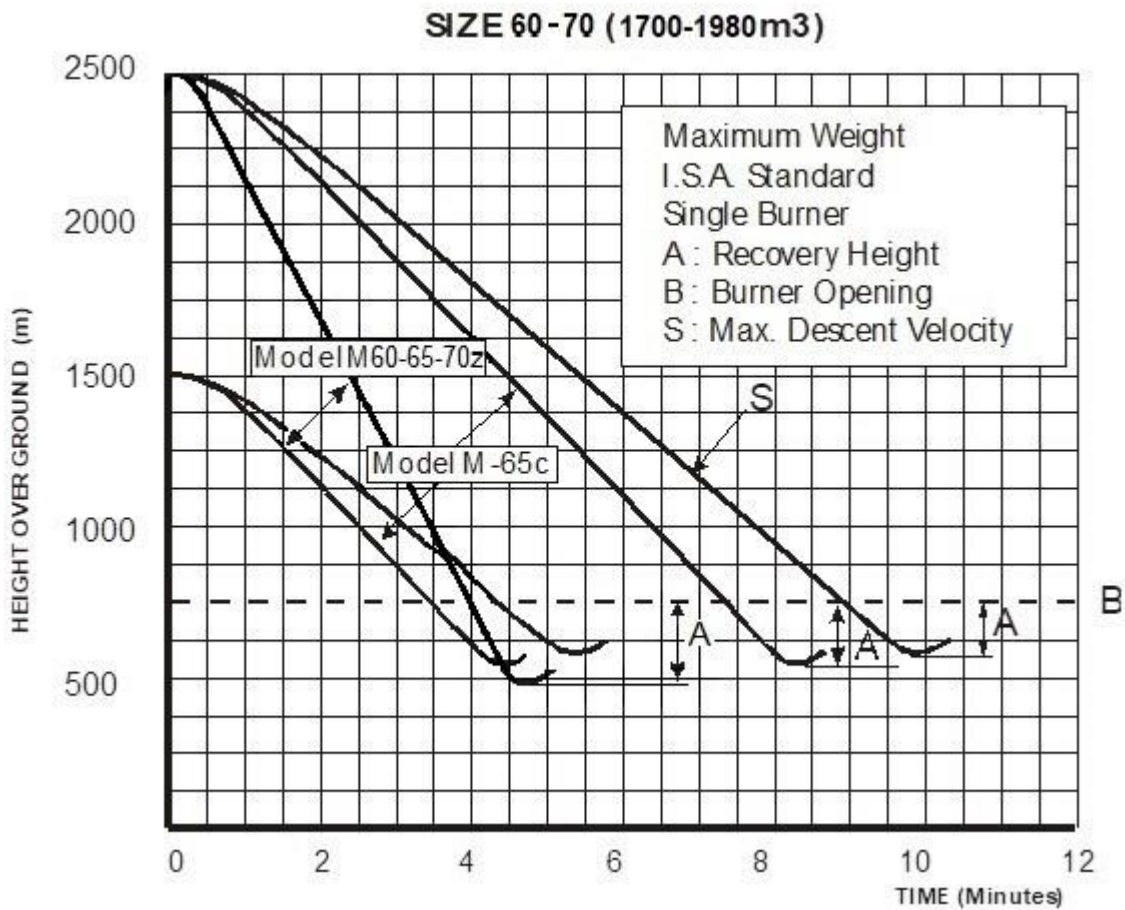
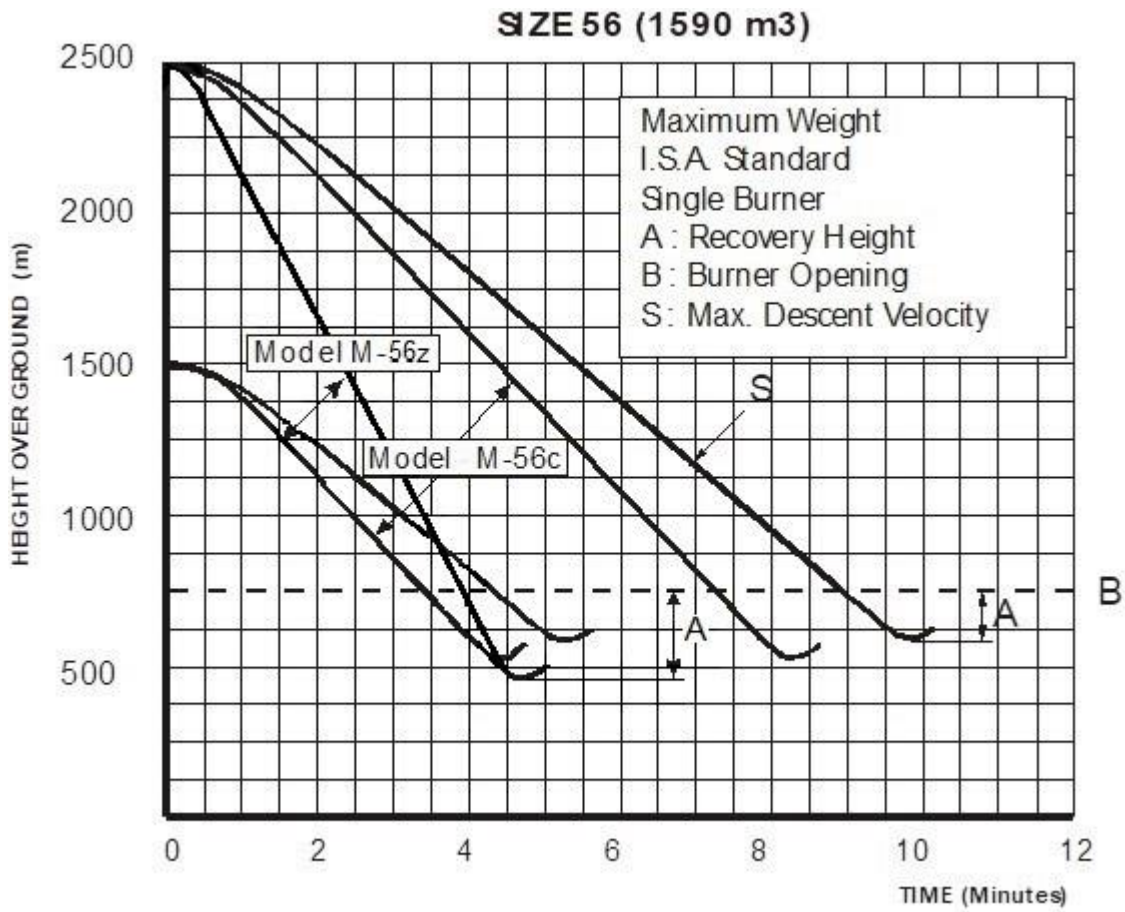

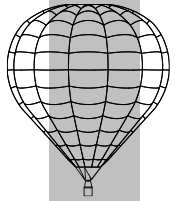

**A
D
E
S
C
E
N
T
P
E
R
F
O
R
M
A
N
C
E
S**

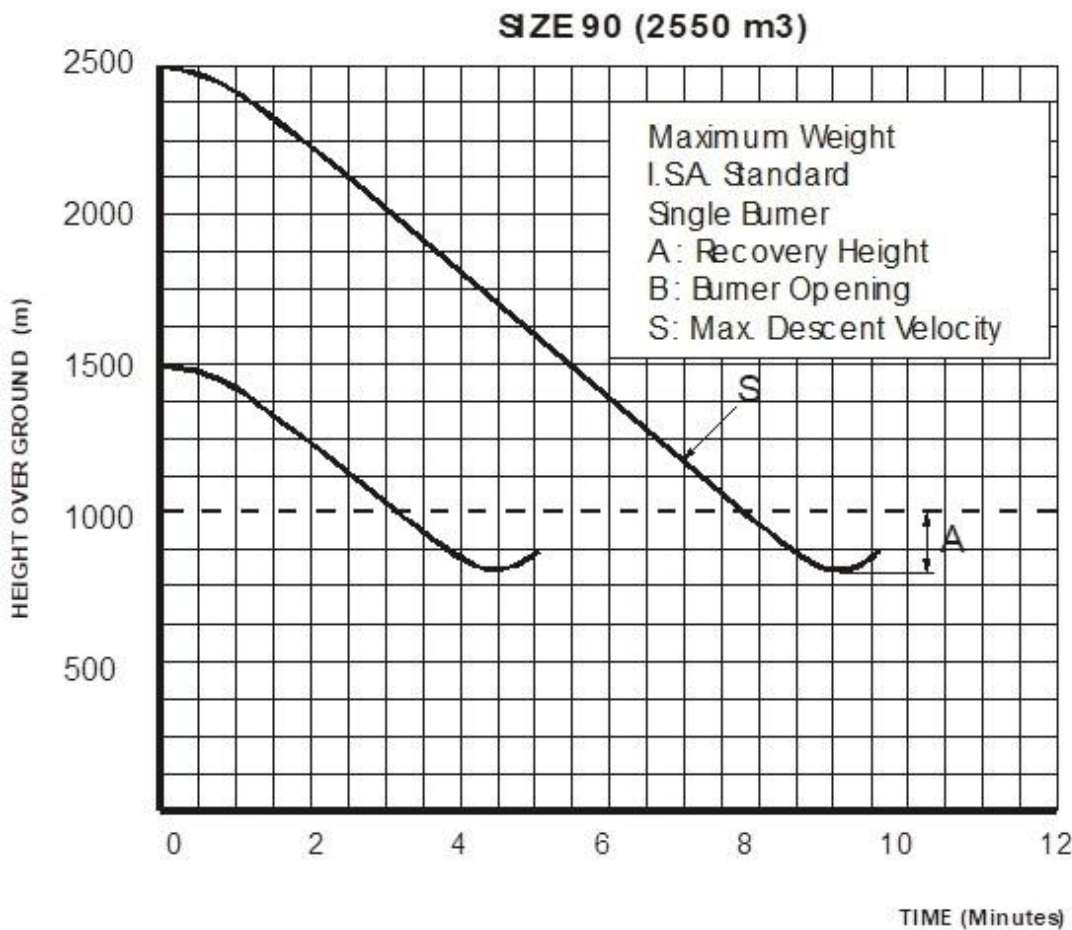
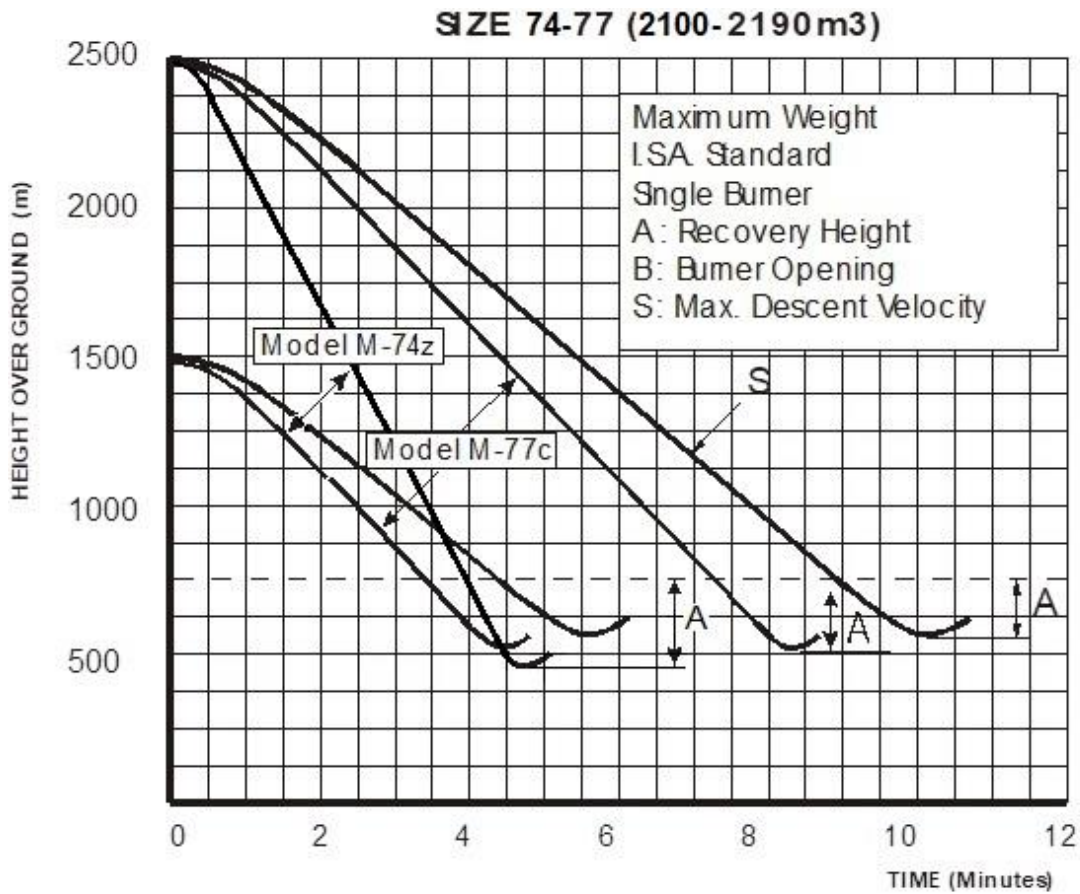

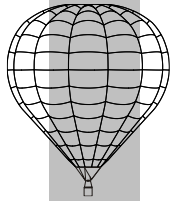

**A
D
E
S
C
E
N
T
P
E
R
F
O
R
M
A
N
C
E
S**

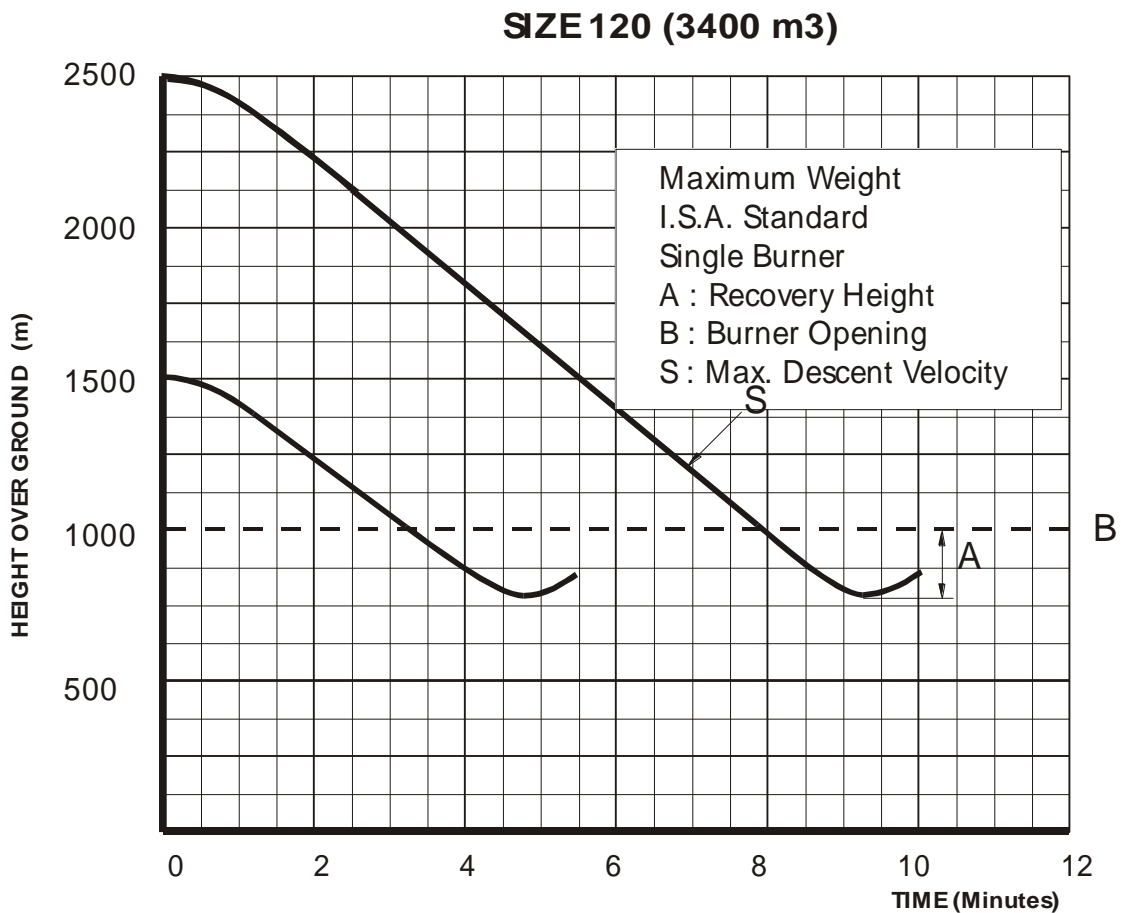
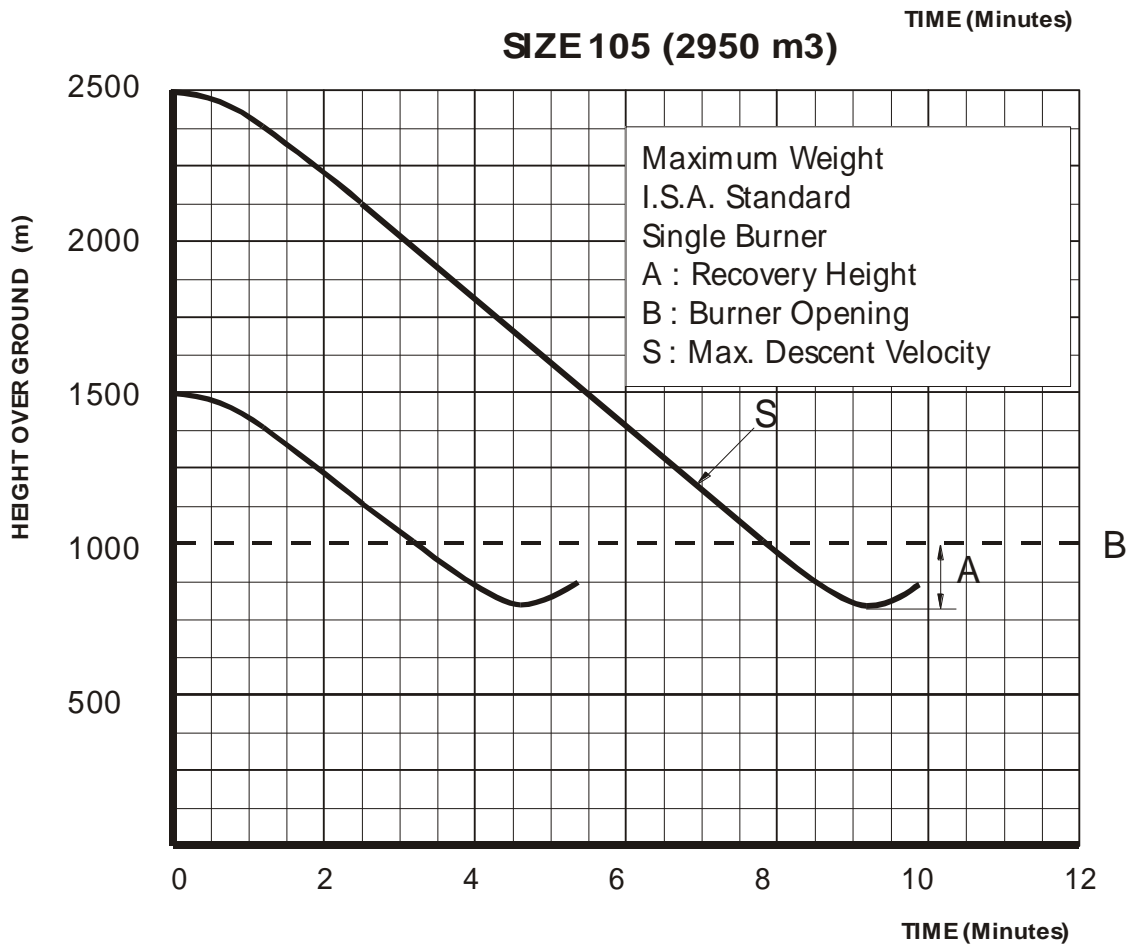

SIZE 130 (3680 m3)

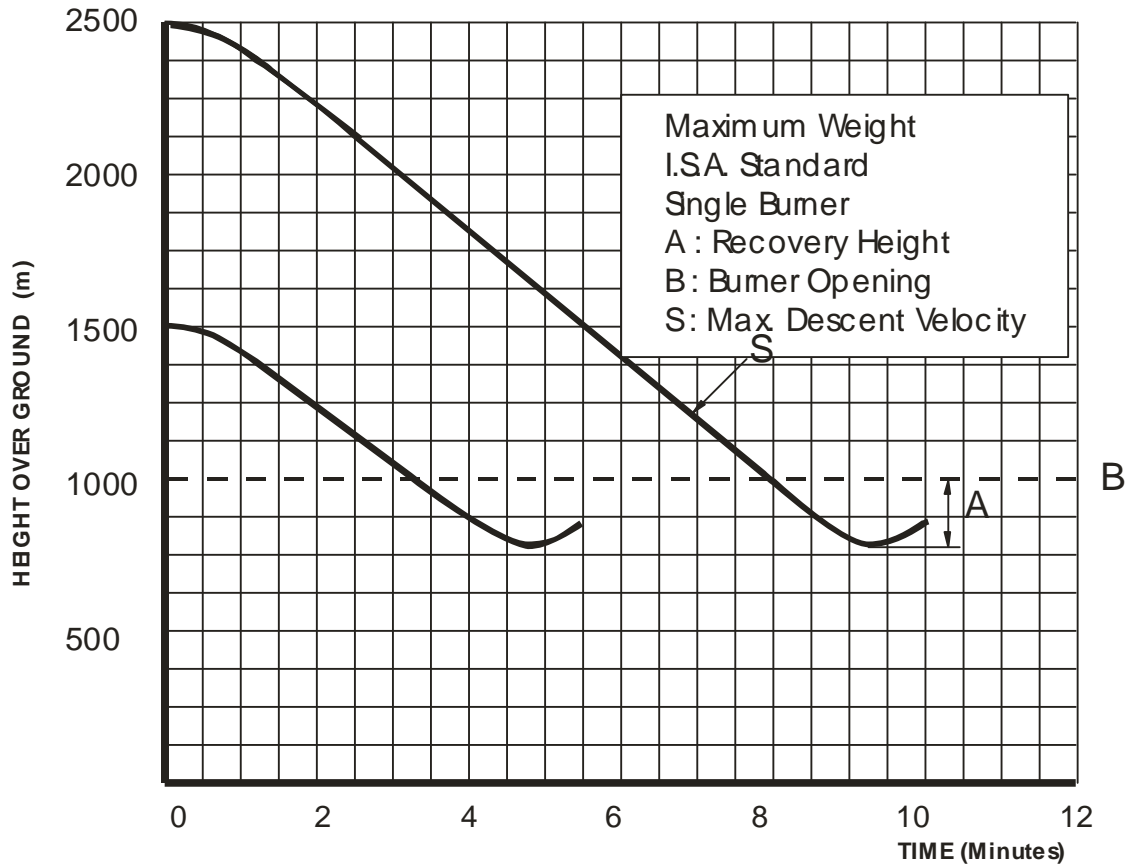

SIZE 145 (4100 m3)

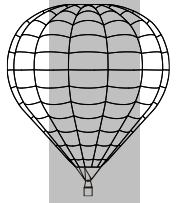
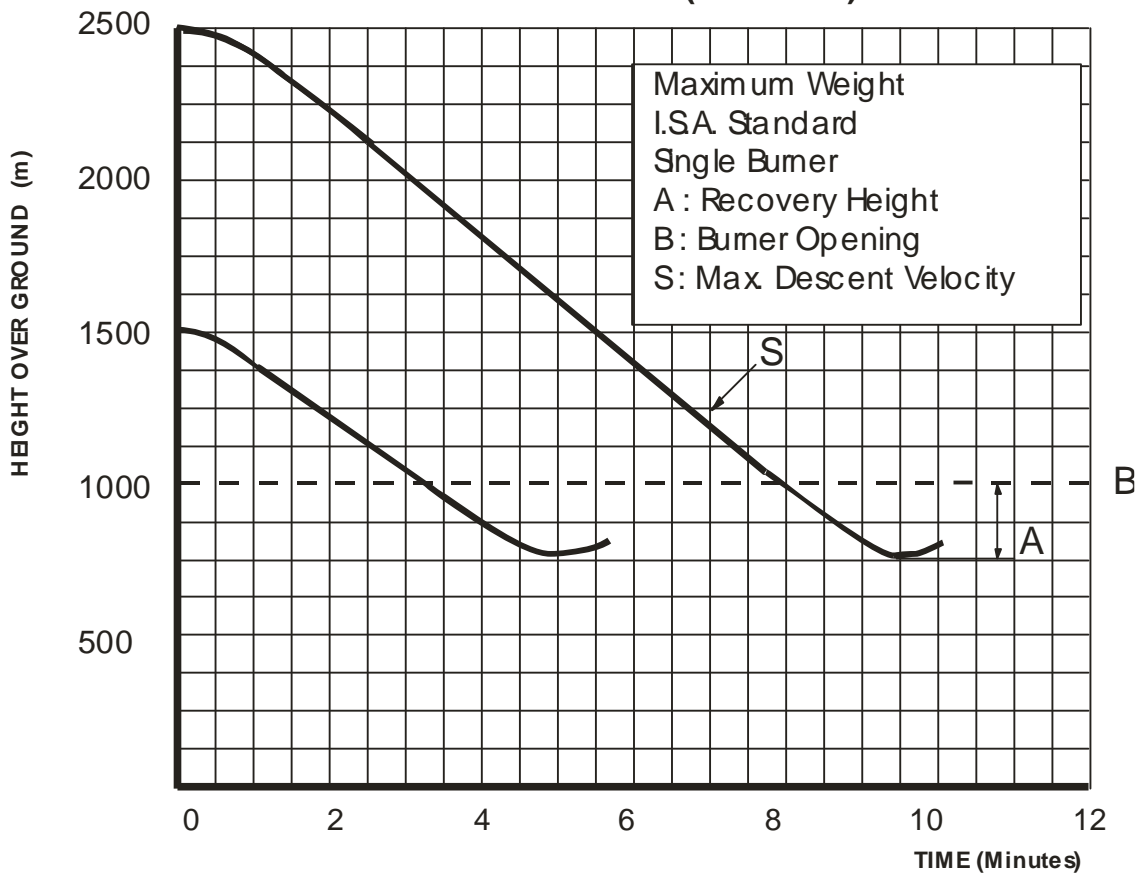

**A
D
E
S
C
E
N
T
P
E
R
F
O
R
M
A
N
C
E
S**

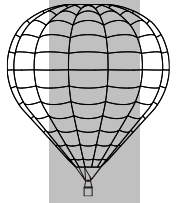

**A
D
E
S
C
E
N
T
P
E
R
F
O
R
M
A
N
C
E
S**

SIZE 150 (4245 m3)

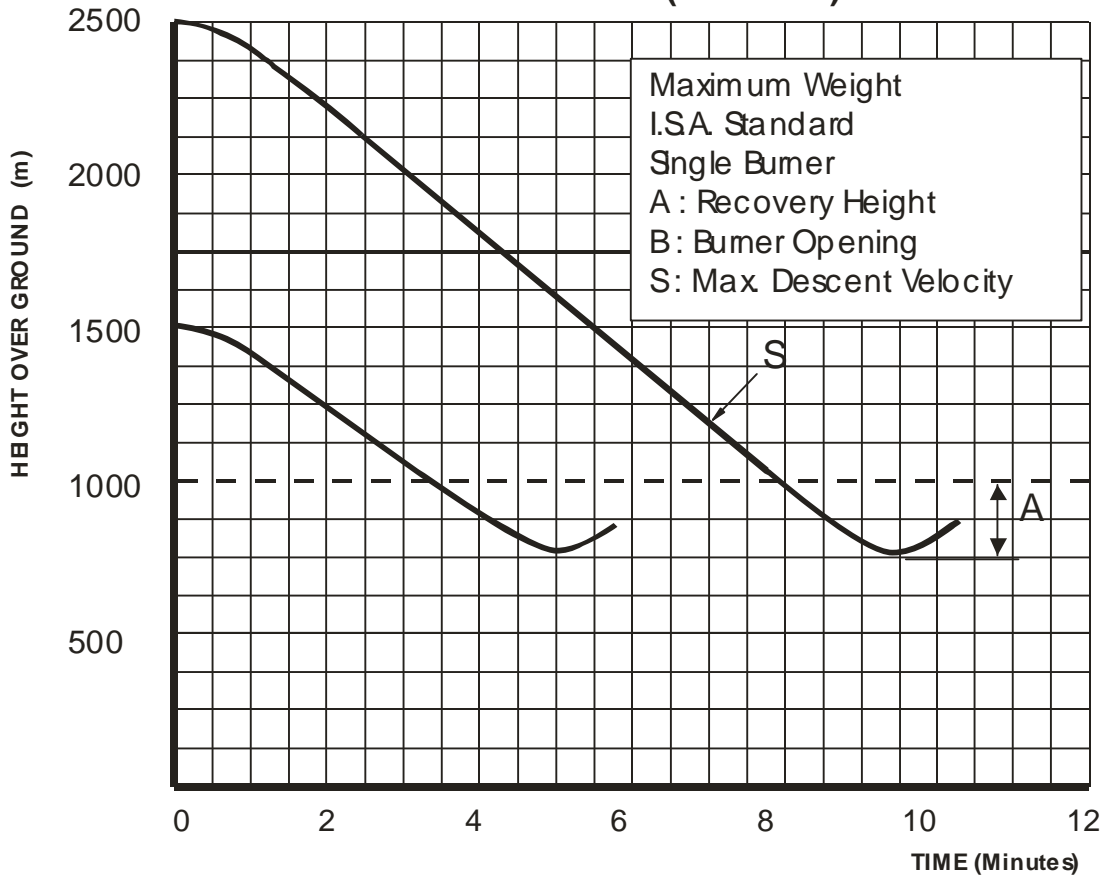

SIZE 160 (4550 m3)

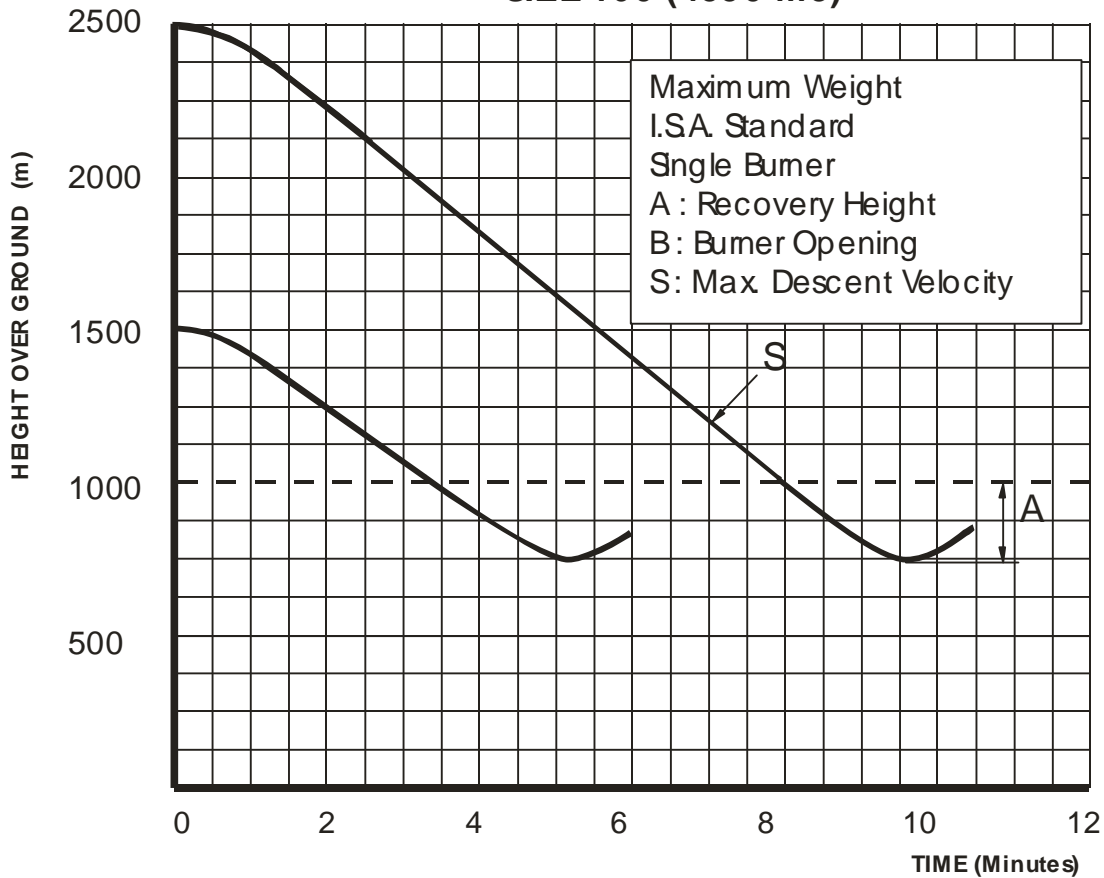

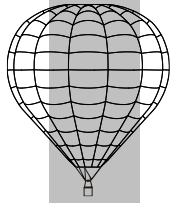

**A
D
E
S
C
E
N
T
P
E
R
F
O
R
M
A
N
C
E
S**

SIZE 180 (5100 m3)

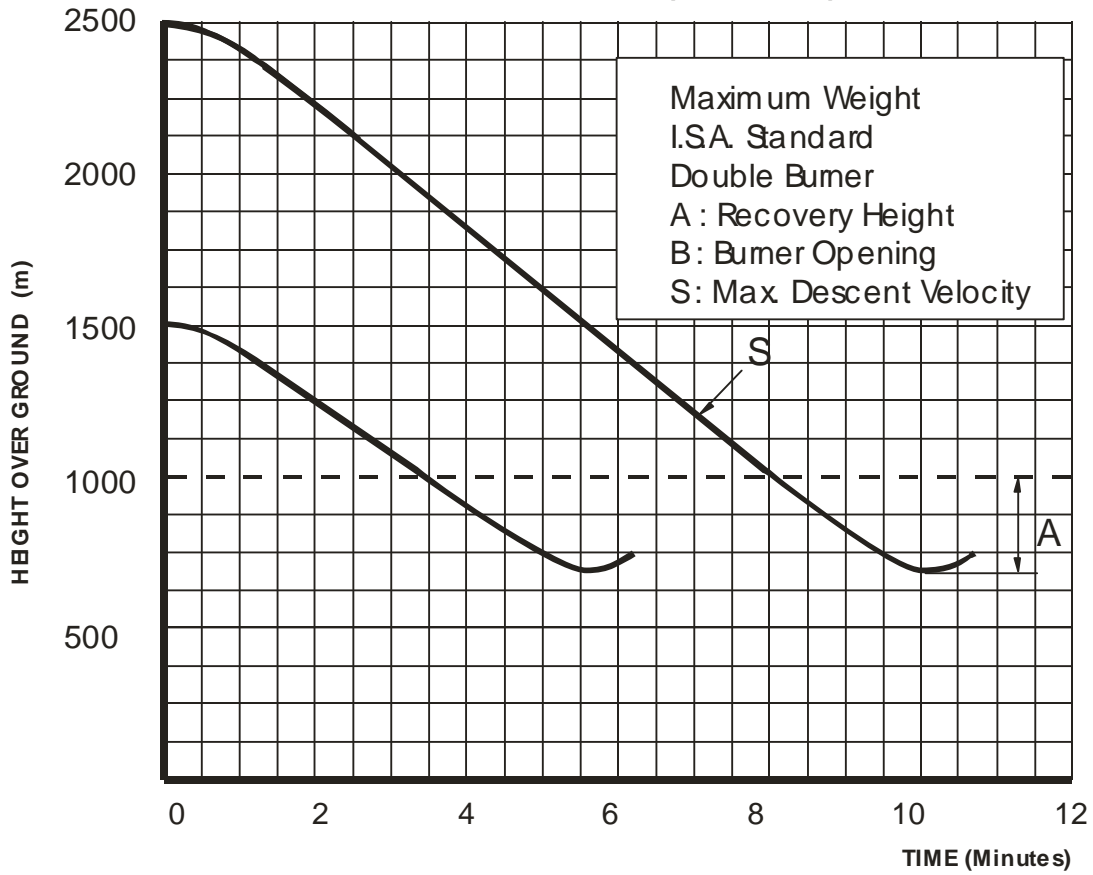

SIZE 210 (6000 m3)

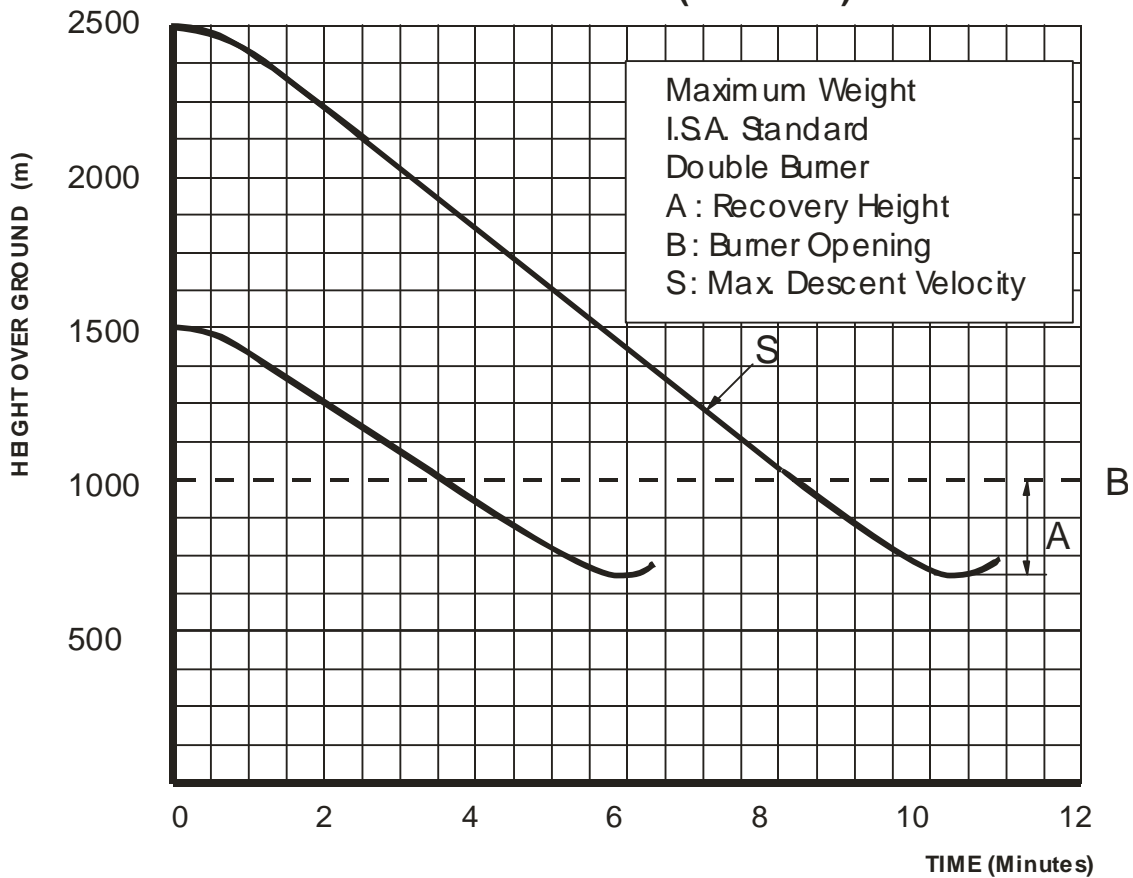

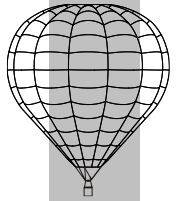

SIZE 250 (7000 m3)

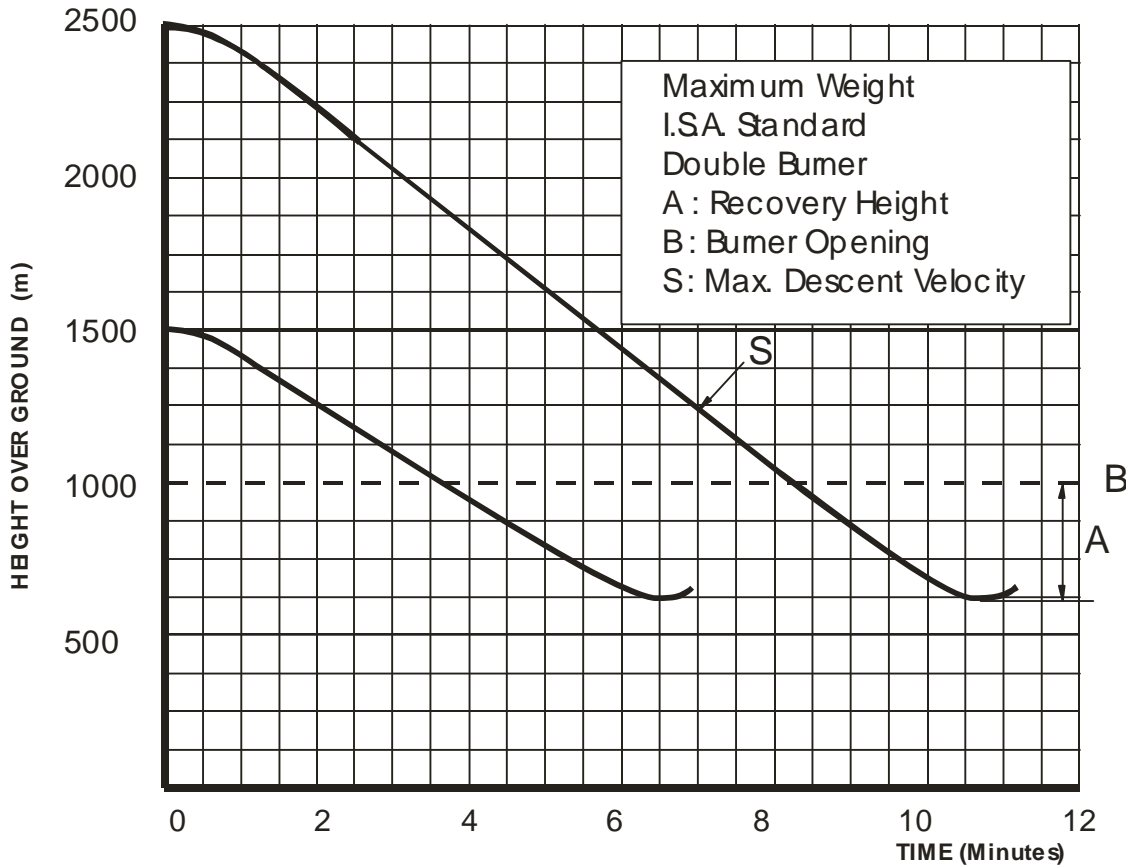

SIZE 300 (8500 m3)

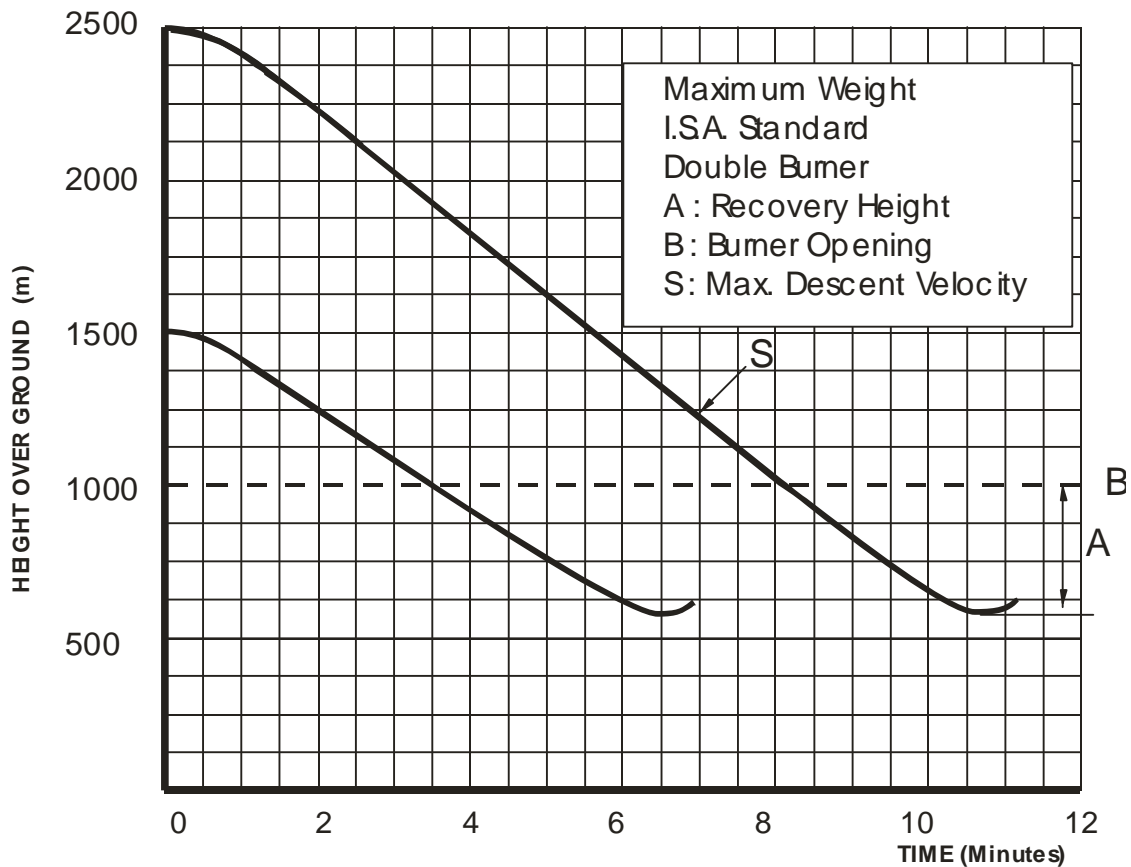

SIZE 350 (10000 m3)

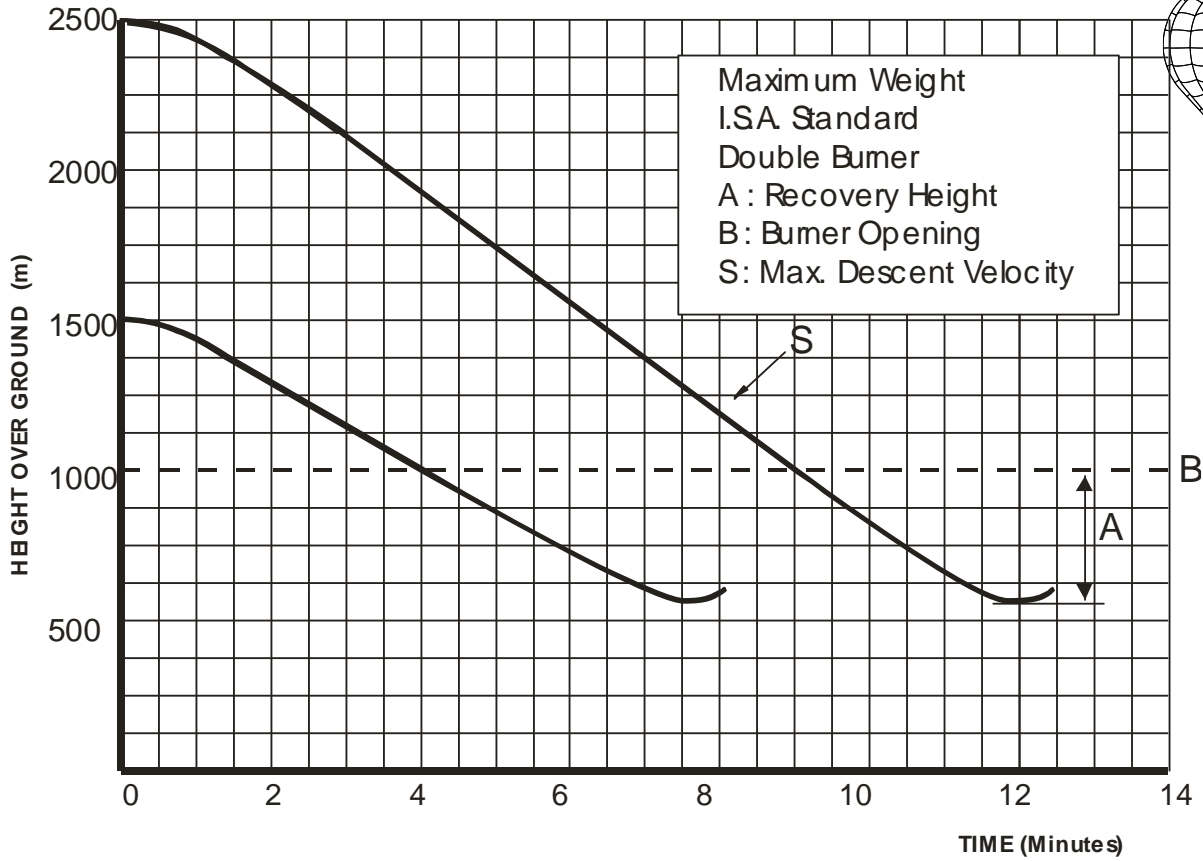

Volume 425 (12000 m3)

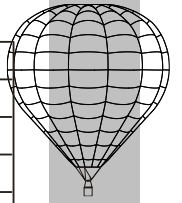
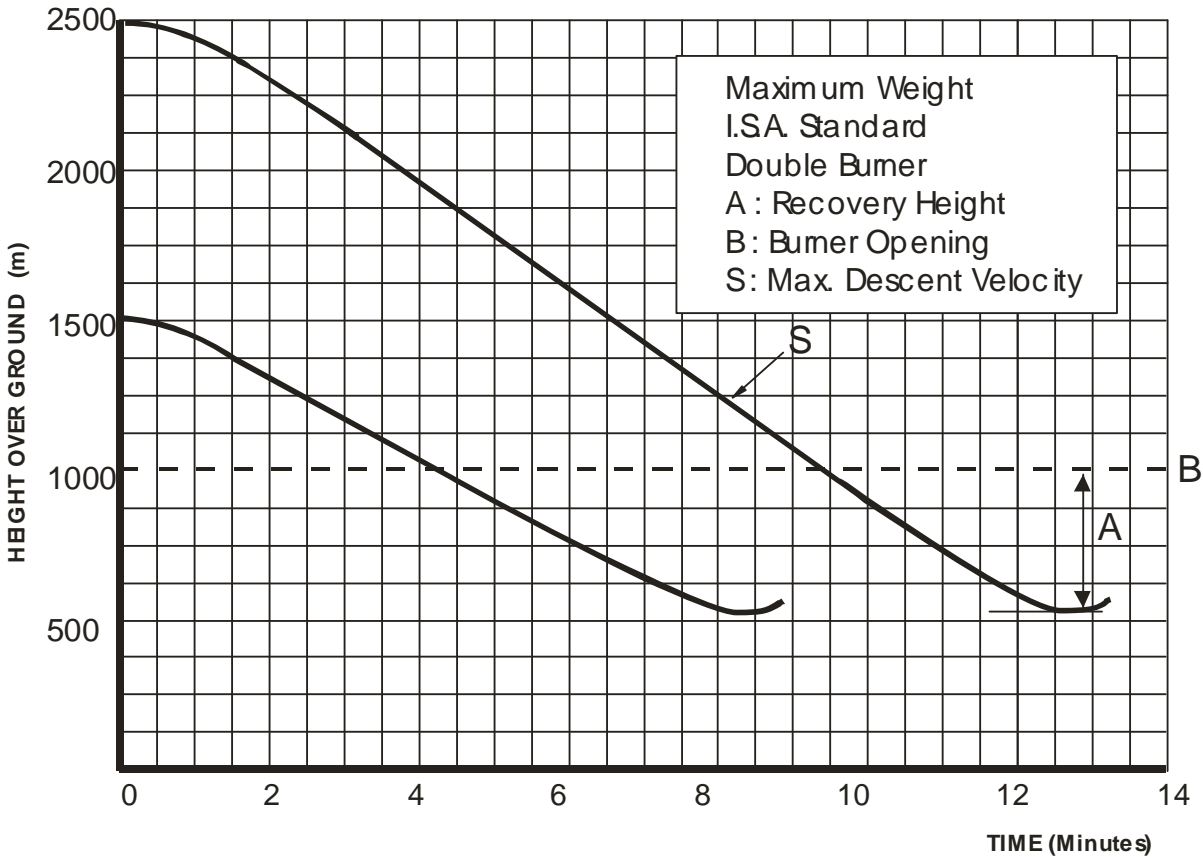

**A
D
E
S
C
E
N
T
P
E
R
F
O
R
M
A
N
C
E
S**

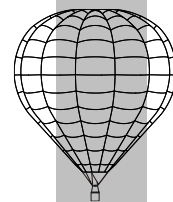

APPENDIX

B – Flight Instruments.

The requirements for the carrying of flight instruments vary from country to country. The carriage of an altimeter and rate of climb indicator is recommended. In some countries a thermistor is also required for measuring internal envelope temperature during the flight. The list shown below indicates instruments that Ultramagic recommend and are generally approved for balloon use. This is by no means a list of the only instruments available for use in Hot air balloons. Ultimate approval for use is subject to the instrument being approved by the appropriate national organization.

Manufacturer	Instrument Model
Flytec	3040 4005
Aircotec	Piccolo 5000 Piccolo 8000
Ball	655 M55 M57
Blue Sky Avionics	Pegasus HA
Brauniger	IQ IQ Balloon Comfort
Winter	
Digital Balloon Instrument	

APPENDIX

C – Quick reference pre – flight checklist.

This appendix may be copied and used as a quick reference in conjunction with Section 4 - Standard Procedures.

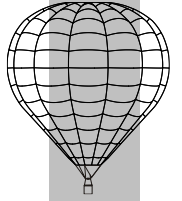

**C
Q
U
I
C
K
R
E
F
E
R
E
N
C
E
P
R
E
-
F
L
I
G
H
T
C
H
E
C
K
L
I
S
T**

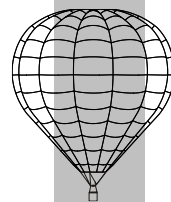

Appendix C - Quick Reference Pre-Flight Checklist.

The following inspections and checks must be carried out before every flight.

Envelope

1. Ensure that any fabric damage does not exceed the Permitted Damage.
2. Ensure that there is do damage to any load tapes.
3. Ensure that there is no damage to the flying wires and that they are free of twists.
4. Ensure that flying wires are connected correctly and that carabiners are closed, screwed shut and loaded lengthways.
5. Ensure that all control ropes and cords are free of damage, securely attached, not twisted and work correctly.
6. Ensure that all pulleys and loops are well attached and are working freely.
7. Ensure that all controls lines are connected to the load frame.
8. Carry out a functional check on parachute system.
9. Carry out a functional check on the FDS rapid deflation system when installed.

Burner and Fuel System

1. Check the burner, all valves and hoses for damage and leaks.
2. Ensure the hoses are connected and secure to the cylinders and that the connections are leak free.
3. Ensure that the cylinders are securely attached, free of damage and that there are no signs of leaks.
4. Check fuel pressure is in accordance with stated requirements.
5. Carry out burner functional check on all burners ensuring all valves open and close correctly.
6. Check that pilot light is burning correctly and is strong and not too noisy or too quiet.
7. Check that all cylinders are functioning correctly.

Basket

1. Check the general condition of the basket for damage.
2. Ensure that the basket wires are free of damage and twists.
3. Ensure that the burner frame and poles fit correctly and are free of damage.
4. Ensure that the attachment points are secure and that all carabiners are screwed locked.

Fuel

1. Ensure sufficient fuel is on board for the required duration of the flight.

Equipment

1. Ensure that the following information and equipment is on board.
 - a) Source of ignition – matches, lighter, striker
 - b) Required maps and airspace and sensitive area information.
 - c) Watch or time piece.
 - d) Instruments – set and working.
 - e) Radio (if used) – set and working.
 - f) Fire extinguisher - in correct condition and at hand.

Passengers.

1. Ensure that all passengers are on board and have sufficient space,
2. Ensure that passengers are briefed for take-off and that all equipment is stowed securely.

Loading.

1. Check the load calculations are in accordance with requirements.

Pilot Restraint

1. Ensure belt is worn and connected (If required)

General Conditions

1. Ensure downwind area is still free of obstacles.
2. Ensure weather conditions have not changed to the detriment of the safety of the flight.

**C
Q
U
I
C
K
R
E
F
E
R
E
N
C
E
P
R
E
-
F
L
I
G
H
T
C
H
E
C
K
-
L
I
S
T**

APPENDIX

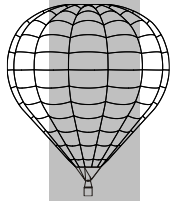

**D
M
I
N
I
M
U
M
B
A
S
K
E
T
S
P
A
C
E
R
E
Q
U
I
R
E
M
E
N
T
S**

D – Minimum basket space requirements.

For safety and comfort reasons a minimum space in the basket must be available for each occupant. The following tables lists the number of persons that may occupy a basket of a particular size taking into account the number of fuel cylinders being used for the flight.

The basket model number quoted is the Ultramagic number with the size in brackets. Where another manufacturers basket has been approved for use then the equivalent size should be used for reference.

Where the basket has a separate pilot compartment it is permissible to carry a passenger in this compartment dependant on the number of cylinders being used for the flight. This can be seen in the separate column titled “Pilot Compartment”

So for example a C7 basket with 4 cylinders may have 2 persons in the pilot compartment including the pilot as well as 6 persons in the passenger compartment. However with 5 or more cylinders in the pilot compartment then only one person is allowed in the pilot compartment, this being of course, the pilot.

MODEL	N Cyl	N Pers	MODEL	Pilot Compartment		N Pers	
				N Cyl	N Pers		
C0 (0.8x0.7m) (31x28 in)	2	1	C7 (1.4x2.0 m) (55x79 in)	2	2	6	
				3	2	6	
				4	2	6	
				5	1	6	
				6	1	6	
				7	1	6	
C2 (1.0x1.0 m) (39x39 in)	2 3 4 5 6	2 2 1 1	C5 (1.4x2.2 m) (55x87 in)	2 3 4 5 6 7 8	3 2 2 1 1 1 -	C Type	T Type
						8	7
						8	7
						8	7
						8	7
						8	7
C1 (1.2x1.0 m) (47x39 in)	2 3 4 5 6	3 3 2 2 2	C8 (1.5x2.6 m) (59x102 in)	2 3 4 5 6 7 8	2 2 2 1 1 1 -	10	
						10	
						10	
						10	
						10	
						10	

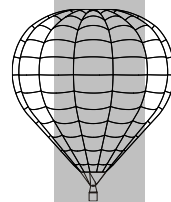

**D
M
I
N
I
M
U
M
B
A
S
K
E
T
S
P
A
C
E
R
E
Q
U
I
R
E
M
E
N
T
S**

MODEL	N Cyl	N Pers	MODEL	Pilot Compartment		N Pers	
				N Cyl	N Pers		
C3 (1.3x1.1m) (51x43 in)	2	4	C9 (1.6x3.0 m) (63x118 in)	2	2	12	
	3	3		3	2	12	
	4	3		4	2	12	
	5	3		5	1	12	
	6	2		6	1	12	
					7	1	12
			8	-	12		
C10 (1.45x1.15 m) (57x45 in)	2	4	C11 (1.7x3.5 m) (67x138 in)	2	3	16	
	3	4		3	3	16	
	4	4		4	3	16	
	5	3		5	2	16	
	6	3		6	2	16	
	7	3		7	2	16	
	8	2		8	1	16	
					9	1	16
			10	1	16		
C4 (1.6x1.2 m) (63x47 in)	2	5	C6 (1.8x1.3 m) (71x51 in)	2	1	6	
	3	5		3	-	6	
	4	5		4	-	6	
	5	4		5	-	6	
	6	4		6	-	5	
	7	4		7	-	5	
	8	3		8	-	5	
	C12 (**)						
1.5X4.0 m (59x157 in)	P C		1.7x4.5 (67x177 in)	Pilot Compartment		N Pers	
	N B	N P		N Cyl	N Pers		
	2	2		16	2	3	20
	3	2		16	3	3	20
	4	2		16	4	3	20
	5	1		16	5	2	20
	6	1		16	6	2	20
	7	1		16	7	2	20
	8	-		16	8	1	20
					9	1	20
			10	1	20		

* Baskets with Pilot Compartment add the corresponding pax. to the pilot/gas Compartment.

* If the removable partition on C-6 or C-7 is out, the maximum number of pax. is 6.

**If measures of C-12 are different, it will be taken the equivalent