

Supplement 16 - MK 21 Burner, Centre Gimbal

16.1 General Information

This supplement details the instructions and limitations necessary to ensure the safe operation, maintenance and continued airworthiness of the Ultramagic MK 21 Burner when fitted with a Centre Gimbal Assembly.

The Centre Gimbal eliminates the need for an inner frame when used with the MK 21 double, triple and quad burners. Since the Gimbal Assembly changes the method of burner attachment to the burner frame, the burner frames have been re-designed to eliminate the inner frame and provide mounting with the use of a central tube. The Gimbal Block Assembly is shown in Figure 1 in the double burner configuration.

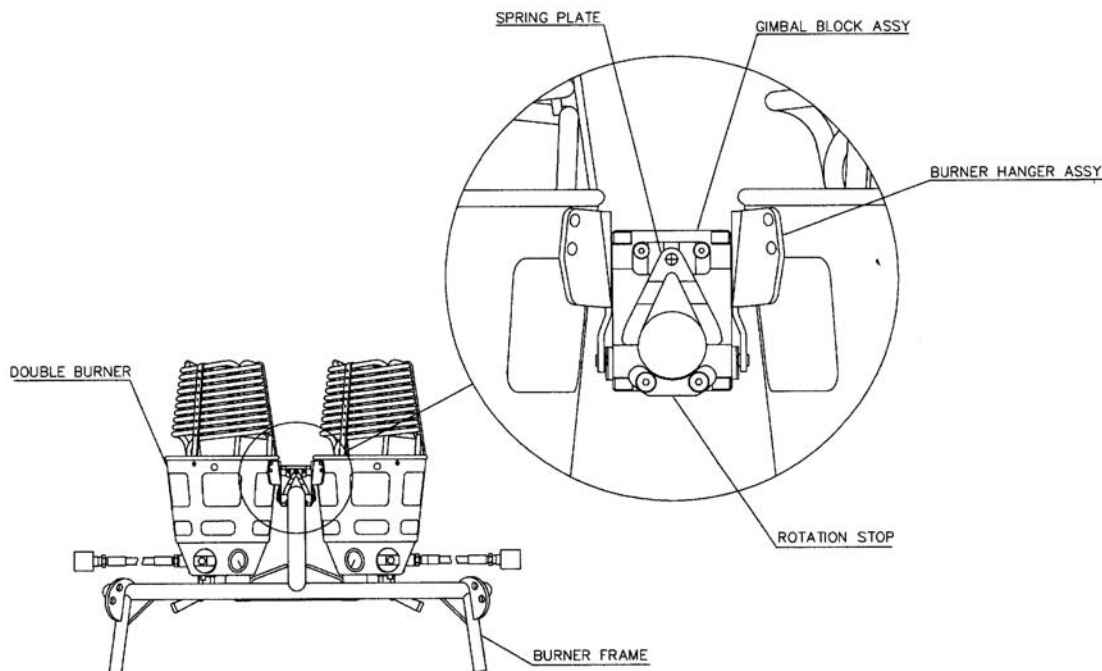
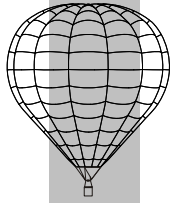

Figure 1

The Gimbal Assembly is provided with a mechanical detent mechanism. This provides the pilot with an indication that the burner is positioned vertically. For the double burner, the detent is provided in both axes. Due to the different balance requirements for the triple and quad burners, the detent is only provided in one axis. However, the triple and quad burner mounting is provided with tension gas springs which automatically return the burner to the vertical in the other axis, when released.

**16.2 Operational Limitations**

No change

16.3 Emergency Procedures

No change.

16.4 Normal Procedures

No change.

16.5 Loading

No change.

16.6 Balloon and Systems Description

No change.

16.7 Balloon Maintenance, Handling and Care

No change

16.8 Other Manufacturers Equipment

No change.